

DRILL MASTERS

Lidoro Tool

PRODUCT CATALOG



WORLDWIDE
SUPPLIER

1-800-658-8855

www.dmetool.com

**DEEP HOLE GUNDRILLS
and
ASSOCIATED PRODUCTS**

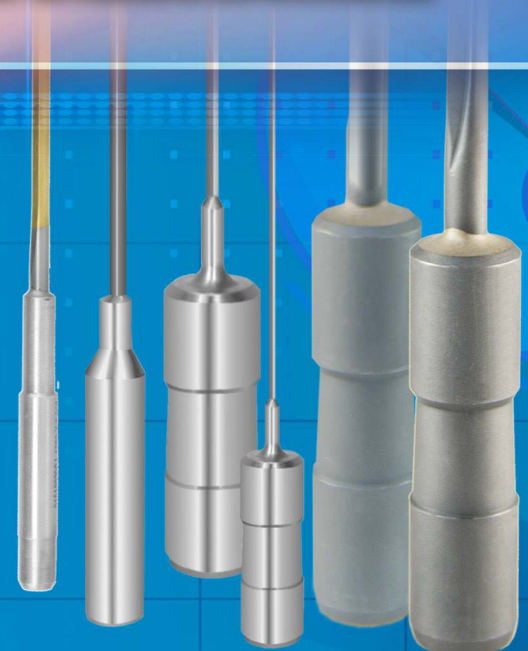

TABLE OF CONTENTS

The Gundrilling Process.....	3
The Anatomy of a Gundrill.....	4
Gundrilling on Non-conventional Machines.....	5
Single Flute, Step Gundrills & Reamers.....	6-7
Contours.....	8-9
Indexable Gun Drill.....	11
Interlocking Detachable Cutting Heads.....	12
Eldo-Loc Detachable Tips.....	13
Reconditioning Tools.....	14
Gun Barrel Tooling.....	15-16
Sharpen Fixtures & Machines.....	17-18
Collet Inserts.....	19
Driver Style Overview.....	20-21
Chip Deflectors & Drill Guides Overview.....	22
Gun Drill Bushings.....	23
Stock Gundrills	
Chip Deflectors.....	24
Drill Guide Parts.....	25
Kidney Coolant Hole.....	26-31
Two Coolant Hole.....	31-37
Solid Carbide Gundrills.....	38-41
Gundrill Speeds, Feeds & Coolant Pressures.....	42-43
Gundrill Problem Solving.....	44
Operation Formulas & Conversions.....	45
Customer Worksheets.....	46-47



Until after World War II, there were no domestic manufacturers of gundrilling tools or machines in the United States. In 1948, this gap was filled when Eldorado Tool was founded to manufacture cutting tools for deep hole drilling. As they were recognized for the quality of their work and innovation of their designs, Eldorado was asked to design and develop tools for deep holes in a variety of metals used in a wide variety of manufacturing fields.

The company's reputation and range of products grew through the 1950s. In 1961, Eldorado developed a full line of standard gundrilling machines. In the 1970s they became the first to introduce a complete line of deep hole drilling tools, machines, fixtures and accessories for the metalworking industry.

During this period, Drill Masters, which had originally been founded as a tool manufacturer, evolved into a respected supplier of deep hole drills and accessories for the automotive, aerospace, firearm and molding industries. Both companies developed customer demonstration and training lab facilities, then added gundrilling production services.

By the year 2000 Drill Masters and Eldorado had become two of the leading designers and manufacturers of deep hole drilling tools, machines, fixtures and accessories. Their experience and knowledge of deep hole drilling techniques in almost any material and configuration had made their products and services sought after by a wide range of industries throughout the United States and the entire world.

The combining of these two leaders in 2002 has made Drill Masters-Eldorado Tool one of the largest suppliers and manufacturers of deep hole drilling tools, fixtures and accessories in the world. Our combined expertise and resources offer you the widest selection of in-stock drills, and the greatest range of products, services, and experience... all made in the U.S.A. Add our rapid delivery and expanded customer service facilities, and you'll see why we're the leader in gundrilling for parts, service, and innovative assistance.

MISSION STATEMENT

Quality First Since 1971

Drill Masters Eldorado Tool is committed to implementing quality processes to identify and meet customer expectations.

We have a built a relationship with our customers and suppliers to ensure that quality has never been compromised.

Evaluating each customer's needs and capabilities has been vital to accomplishing this goal.

Deep hole drilling was first developed for the manufacturing of firearms, hence the name gundrilling. Originally a time-consuming and expensive process, technological advances have made it a highly efficient manufacturing process utilized in all metal cutting industries, including automotive, aircraft, aerospace, construction, medical, tool and die, petro chemical, hydraulics, pneumatics and more.

Gundrilling is an ideal solution for most deep hole and high-precision drilling projects. This operation produces accurate, repeatable holes with excellent surface finishes. Gundrills hold location to precise tolerances, are sized to exact specifications, produce burr-free holes and can be formed to produce specific shapes in blind holes and bottom forming with a minimum of machine adaptation. These systems can be easily integrated with CNC machining centers, lathes and milling machines for a relatively small investment, making it affordable for large or small shops with production requirements varying from one piece to hundreds of thousands.

The gundrill's function

Gundrilling is a metal removal process involving a drilling machine, a high pressure coolant system and a high quality drill with a single or double flute along the shank. In operation, the drill is positioned and held in the spindle nose, then guided into the workpiece through a prestarted hole or guide bushing to prevent vibration and ensure accuracy. The drill tip's cutting edges produce thin curled chips that are carried back along the shank by the high pressure coolant and deposited in the chip box. The off-center design of the cutting edges creates pressure within the bore, which is carried by pads behind the drill tip. The coolant that flushes out the chips also lubricates these pads, which burnish the surface and develop the fine finish for which gundrilling is known.

The gundrilling machine

Designed to provide optimum conditions for gundrill operation, the gundrilling machine's high pressure pump delivers lubricant to the rear of the drill. The drill can be driven by the spindle or be held stationary if the workpiece is rotated. During drilling, the workpiece can be advanced or the drill can advance.

The gundrill is supported by anti-whip devices along the shank and at the rear of the chip box. The chip box contains chip deflectors and a front end bushing which guides the drill into the workpiece.

THE GUNDRILLING PROCESS

- **Straightness tolerances of .001" (.025mm) per foot.**

- **Concentricity tolerances of .001" (.025mm) per inch or better.**

- **Hole diameter tolerances of +/- .0005" (.0127mm)**

- **Finish tolerances as low as 4 Ra.**

- **Burr-free intersections**

- **Consistent reproduction from hole to hole.**

THE ANATOMY OF A GUNDRILL

The gun drill is a simple basic tool consisting of a carbide tip, a heat treated alloy shank, and a steel driver, typically silver brazed together into one precision unit.

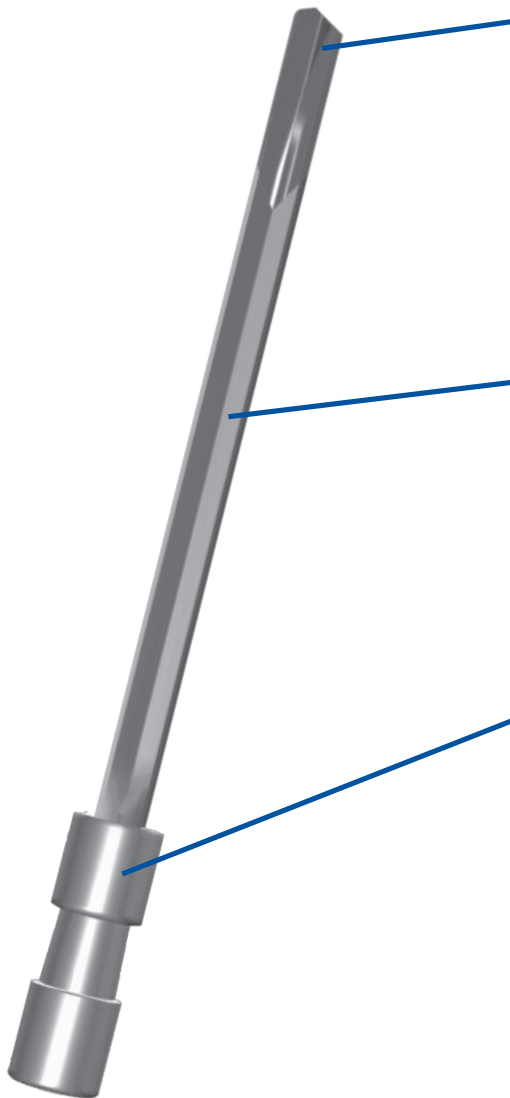

Tip: The most critical element, the tip cuts the hole as it pilots the drill through the workpiece, producing precision holes in a single pass. The drill's point, or nosegrind, has two basic angles that may be varied for optimum results depending upon the material being drilled. These angles balance cutting forces, distributing them to the tip's bearing pads to keep the drill concentric. The tip is slightly larger than the shank, so the shank can rotate freely without contacting the hole wall. A round, kidney-shaped, or two round holes-through-the-tip line up with the shank's channel to allow the flow of coolant at high pressures.

Shank: The shank is made from aircraft grade alloy steel tubing with a 110°-120° vee-flute formed to the center of the shank's diameter. Coolant is forced from the driver through the center of the shank to the tip, where it is flushed back along the shank's flute. The shank maintains proper gundrill alignment and must be strong enough to absorb cutting torque and thrust. If the shank is too stiff it may transfer minor mis-alignment in the machine to the tip, but it must not be flexible enough to sag or whip at high RPMs.

Driver: Drivers are cylindrical, with an undercut or flat section for the set screw, which holds in the spindle bore. They are manufactured to industry standards or to special diameters and a concentric hole through the driver's length allows coolant to pass through to the shank and tip.

Diameter range	2.0 - 70.00 mm
Length	Up to 6,000 mm
Effective tool length	40-50 x ϕ
Cooling lubricant (coolant) required	
Deep hole drilling oil preferred	
Filter resolution	10-20 mm
Viscosity	ϕ 1.9-50 mm = 10-20 mm ² /S

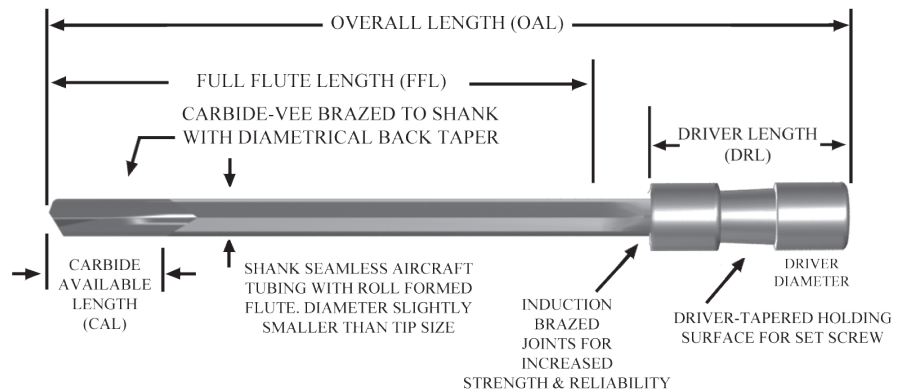

**GUNDRILLING ON
NON-CONVENTIONAL
MACHINES**

SOLID CARBIDES

SCREW-MACHINES, MACHINING CENTERS, LATHES, ETC.

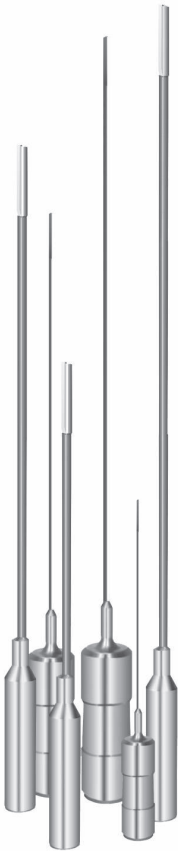

Solid Carbide Gundrills are manufactured as a single piece of carbide. The tip and tube is a single piece which eliminates the braze joint at the head and tube transition resulting in an extremely strong, ridged tool.

The major advantage in using Solid Carbide drills is you can maximize the surface footage and feed rates due to their rigidity.

Solid Carbide Drills are available on our shelves in stock-standard diameters from .03937" (1mm) - .3750" (9.525 mm) and lengths from 5" - 18"; we offer shortest lead times in the industry on specials, 4-weeks.

THE RIGHT DRILL FOR THE RIGHT APPLICATION

The gundrilling process is commonly utilized on virtually any machine that incorporates through-the-spindle-high-pressure-coolant.

The tool selection and operation sequence is the same as a conventional Gundrill machine with the exception that a pilot hole is needed to replace the starter bushing (GDI) to support the tool as it enters the part. The general pilot hole rule-of-thumb is two-times diameter in depth and .0002" -.0005" larger in diameter, preferably with a flat bottom form.

Diameter range	1.0-9.525 mm
Length	Up to 350 mm
Effective tool length	80-100 x ϕ
Cooling lubricant (coolant) required	
Deep hole drilling oil preferred	
Filter resolution	5-10 mm
Viscosity	ϕ 0.6-2.0 mm = 7-10 mm ² /S ϕ 2.0-12 mm = 10-20 mm ² /S

SINGLE FLUTE GUNDRILL TYPES

Drill Masters-Eldorado single flute gundrills are available in diameters from .03937" (1.00 mm) to 3.000" (76.20 mm). Included in this range are over 800 sizes and lengths available for same day delivery. We also offer an expedited service for non-stock gundrills to satisfy your urgent requests. As part of our Quality Assurance program, our carbide and steel tubing are subjected to complete metallurgical analysis prior to manufacturing the final product. In addition to the single flute design, we offer two flute, solid carbide tip and shank, Opti-Flo (kidney oil hole), and Opti-Flo II (two oil hole) gundrills. Shown here are some of the popular gundrills and gunbores we manufacture.

Style #1

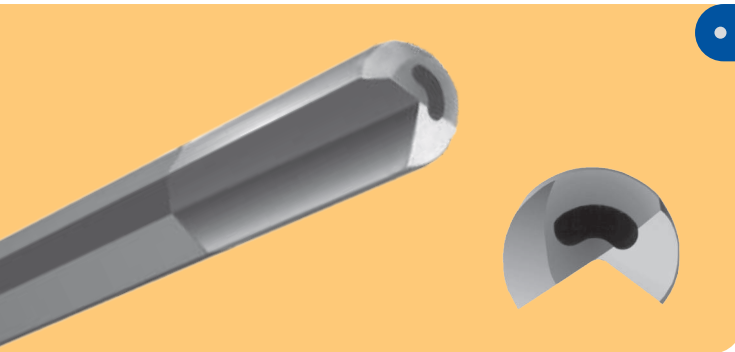

• Single kidney hole, single flute

The Opti-Flo features a carbide tip, available from .0750" (1.905mm) to 0.3174" (8.062mm) in standard stock sizes and lengths for immediate delivery and as special orders to customer specifications.

Style #2

• Two round holes, single flute

The Opti-Flo II features a carbide tip, available from .3018" (7.665mm) to 1.500" (38.1mm) in standard stock sizes and lengths for immediate delivery and as special orders to 3.000" (76.2mm) in diameter "inserted".

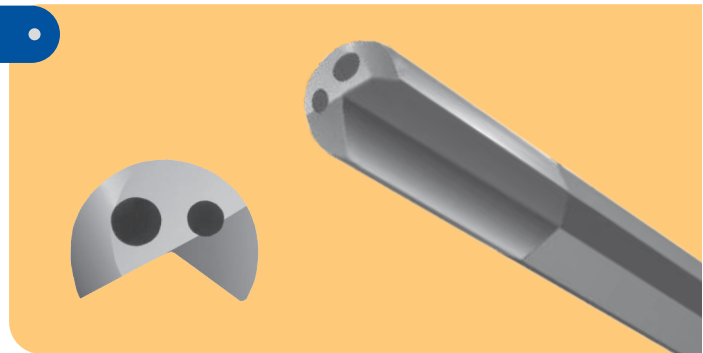

Style #3

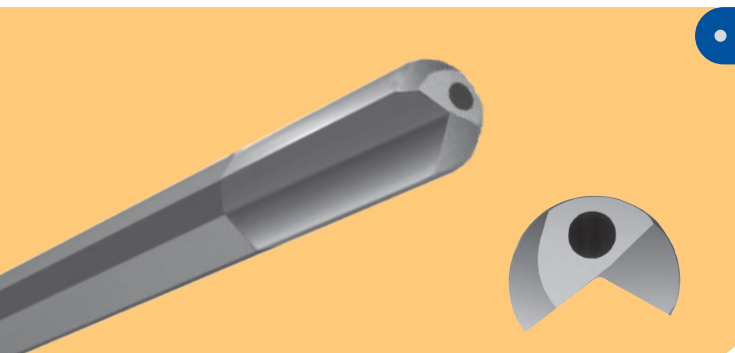

• Single round hole, single flute

Solid carbide tip, available from .0750" (1.905mm) to 0.1875" (4.762mm) in over 800 standard sizes and lengths for immediate delivery and as special orders to 3.000" (76.2mm) in diameter "inserted".

TWO FLUTE GUNDRILL

• Two Hole, Two Flute

Solid carbide tip with tube (shank) manufactured from 4135 aircraft grade tubing. Diameters available from .375" (4.75mm) to 1.25" (31.75mm) and lengths to 84" (2133mm)

Style #4

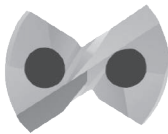

The two flute gundrill design incorporates two cutting edges which reduces chip load and increases penetration rate up to 100% over single flute drills in various non-ferrous applications. They can be used in conventional gundrilling machines and in CNC lathes and machining centers. Two flute gundrill features include:

- Sub-micro grain carbide tips for greater tool life
- 4135 aircraft grade shanks
- Dual oil holes for optimum chip evacuation

Step Tools •

Step tools may be incorporated in an application to eliminate two to three subsequent operations in a single hole. The use of a step tool dramatically reduces cycle time, scrap, and eccentricity between diameters.

Step drills have manufacturing limitations depending on extreme diameter ranges in the steps. Special carbide developing may sometimes be necessary due to the coolant hole location. Additionally chip breakers may be required due to the lack of an inside angle which curls and breaks the chips under normal circumstances. Ideally using this type of drill yields virtually no eccentricity between diameters.

Step Drills are also used with a non-cutting pilot to follow an existing hole and minimize eccentricity between two diameters.

Style #5



MULTI-DIAMETER STEP GUNDRILLS

Many parts require as many as two, three, or four various size holes in a single bore. Certain applications may allow a single multi-diameter gundrill to produce all or some of these holes, reducing machining time.

REAMERS

Chips ahead and behind reamers are commonly used to obtain very tight ID bore sizes. Drilling an initial hole .015" - .030" under the desired finished diameter yields the perfect amount of material to be removed with this type of tool. The result is a hole size to .0002" in diameter and finishes to 16 RMS or better in a single pass, usually eliminating the need for honing.

• Chips Ahead Reamers

Solid carbide tip reamers are available in most diameters and lengths to produce close tolerances, eliminating the need for honing.

Style #6

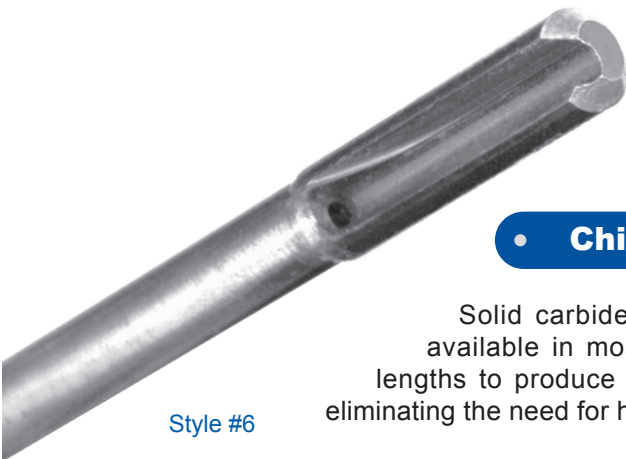

CONTOURS

Contour selection is made on the basis of the material to be drilled, and the details of the particular application. As a rule, the greater the bearing pad's area of contact, the better control of size and finish due to increased support and burnishing action.

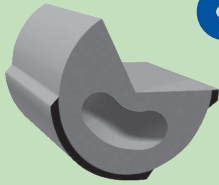

• R1: Standard Bearing Pad

General purpose stock drill contour for steel, stainless steel, inconel and aluminum. Offers minimum bearing contact with the workpiece (non-micable).

• R2: Standard Bearing and Guide Pad

Recommended for all non-ferrous, cast iron and gun-barrel's up to gundrill diameter of .200" (non-micable).

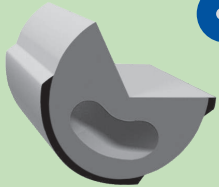
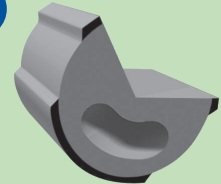

• R3: High Bearing Pad

For good size control (including at exit) special purpose contour, where micable diameter is required or extra burnishing action is required, not for all materials (micable).

• R4: High Bearing and Guide Pad

For use in aluminum and brass for best hole finish and for intersecting holes and interrupted cuts, or extra O.D. support and burnishing. Use with wood and plastic in combination with .0015/.002" back taper. Do not use in high nickel content materials due to high burnishing forces (micable).

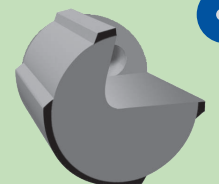
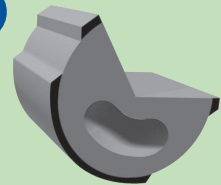

• R6: High Bearing and Guide Pad Reamer

For chips ahead reaming applications when opening up existing holes, e.g., valve guides (micable).

• R9: High Interrupted Bearing Pad

For good size control, including at exit. Special purpose contour where micable diameter is required, or extra burnishing action is required, not for all materials (micable).

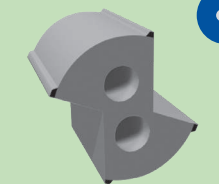
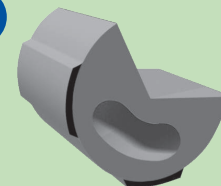

• R10: Two Flute Bearing Pad

Used for high penetration rates in applications such as lubrication holes. Contour for aluminum shown (micable).

The center design of our gundrills allows for a wide range of nosegrinds from a full spherical radius to a flat bottom design. The nosegrind angles are important in attaining the best quality results. Angles can be modified to improve the flushing action of the high pressure oil and to improve chip control. Specific grinds have been developed for severe applications such as exit breakouts and interrupted or angular entries. Some of the most popular nosegrind configurations are shown here.

• N-8 Nosegrind

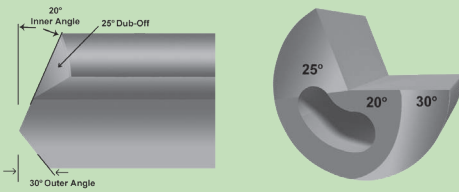

General purpose stock drill grind for steel, inconel and stainless steel, most often used with stock 'R1' O.D. contour.

• N-4 Nosegrind

In aluminum and brass, use this grind with 'R4' O.D. contour for best hole finish.

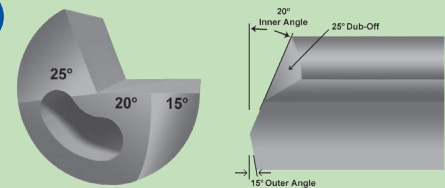

• N-73 Nosegrind

For drilling, stacked parts and angular entries. Due to the point's placement near the center of the drill, this is the strongest gundrill.

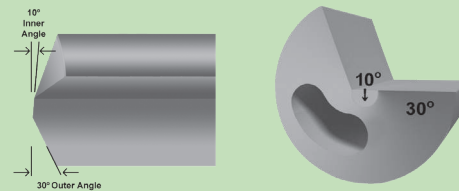

• N-126 Nosegrind

For applications requiring drilling flat bottoms. It can also be ground for a completely flat bottom, or on difficult materials; use to qualify bottoms only.

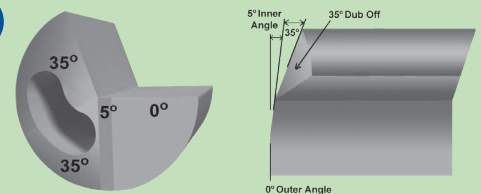

• Facet Nosegrind

Facet grinds are preferred on specific applications, or when regrind fixtures limit the cam type sharpenings. They can be ground to various slash type angles with good performance and allow a greater amount of clearance for coolant to cool the chip at the cutting edge. This grind is standard on most European applications.

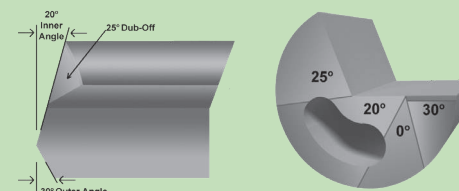

• Chip Breakers

Chip Breakers are generally used to break string type chips often attributed to gummy material or when machines limit the surface footage necessary to generate the heat needed to break a chip.

There are two types of Chip Breakers:
 The **Radial Chip Breaker** runs down the length of the carbide flat and lasts the life of the tool.
 The **Standard Chip Breaker** is reproduced each time the tool is ground.

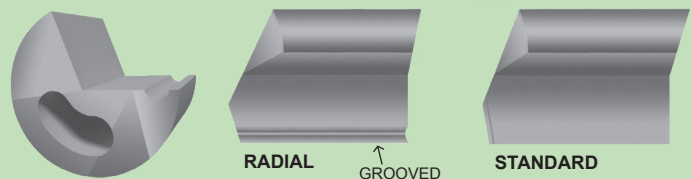

Single Lip drills with indexable inserts WP-ELB Series 10

NEW 2024

Main Advantages:

1. **Versatility to use** on lathe, machining centers and deep hole machines.
1. **High efficiency** by specifically developed cutting edge geometry for ideal chip formation.
1. **Short downtime** resulting from quick exchange of wear parts
2. **Easy to use**, no sharpening, no length adjustment, easy inventory of wear parts.
3. **Long tool life** due to full coating, edge treatment and indexable design
4. **Quick availability** due to stocked wear parts and most common body sizes.



Design:

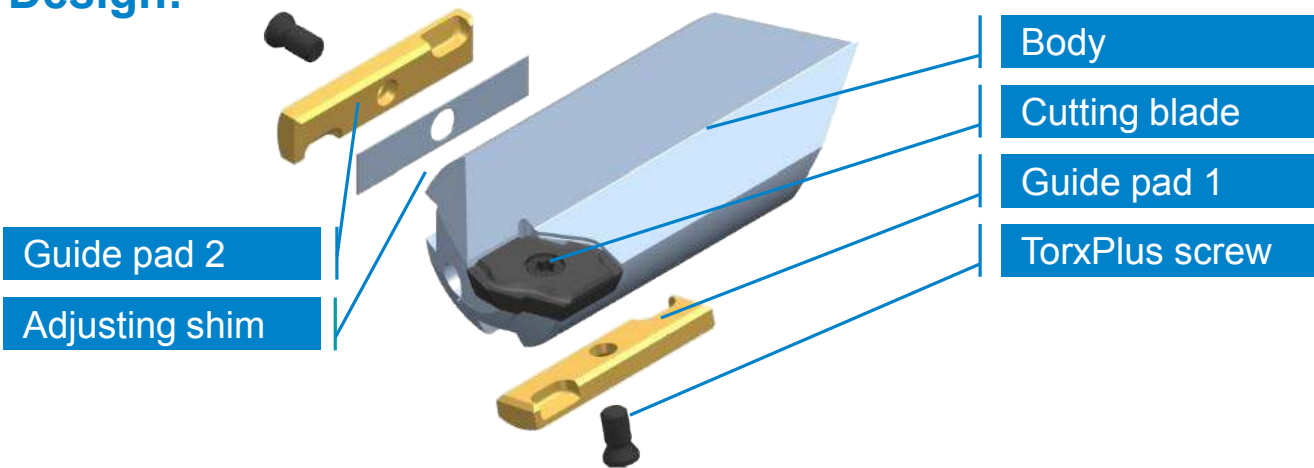

Technical Information:

- Diameter range: 12.00 mm – 28.00 mm
- Cutting blade & guide pads fully coated
- Covering the whole diameter range with only 6 sizes of cutting blades.
- Tool body built in steps of 0.1 mm
- Available with long head and three additional guide
- Adjusting shim available to fine-tune diameter



Single Lip drills with indexable inserts

WP-ELB Series 10

NEW 2024

Inquiries and delivery:

- Please state the required drill diameter, the overall length and the clamping element.
- You will receive your tools fully equipped and ready to use.
- Suitable TorxPlus® drivers for the replacement of wear parts are available as extra

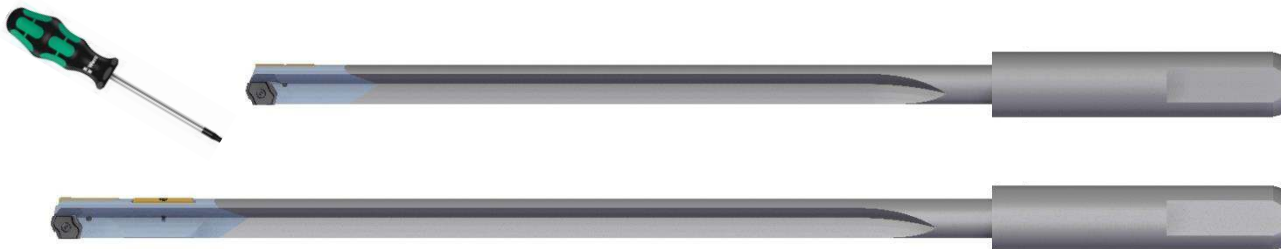

HEADS IN STOCK SHORT AND LONG											
0.4724	INDEXABLE	0.5512	INDEXABLE	0.6250	INDEXABLE	0.7187	INDEXABLE	0.8125	INDEXABLE	0.9844	INDEXABLE
0.4844	INDEXABLE	0.5625	INDEXABLE	0.6299	INDEXABLE	0.7500	INDEXABLE	0.8750	INDEXABLE	1.000	INDEXABLE
0.5000	INDEXABLE	0.5781	INDEXABLE	0.6719	INDEXABLE	0.7656	INDEXABLE	0.9062	INDEXABLE	1.0625	INDEXABLE
0.5156	INDEXABLE	0.5937	INDEXABLE	0.6875	INDEXABLE	0.7812	INDEXABLE	0.9219	INDEXABLE		
0.5312	INDEXALBE	0.6094	INDEXABLE	0.7031	INDEXALBE	0.7874	INDEXABLE	0.9687	INDEXALBE		

Wear Parts overview:

Drill Ø		Cutting insert	Screw Torx Plus®	Guide pad	Screw Torx Plus®	Adjusting shim
von	bis					
12,00	13,99	TSTS-CB2-00 TSTS000199	6IP M2,2x4 TSTS000613	TSTS-GC04A-P TSTS000326	6IP M2,2x4 TSTS000613	TSTS-S04
14,00	15,09	TSTS-CB2-01 TSTS000094	6IP M2,2x4,6 TSTS000614	TSTS-GC05A-P TSTS000091	6IP M2,2x4,6 TSTS000633	TSTS-S05
15,10	17,39	TSTS-CB2-02 TSTS000095	7IP M2,5x5 TSTS000615		7IP M2,5x5 TSTS000615	
17,40	19,79	TSTS-CB2-05 TSTS000098	7IP M3x6 TSTS000616	TSTS-GC06-P TSTS000016	7IP M3x6 TSTS000616	TSTS-S06
19,80	23,89	TSTS-CB2-07 TSTS000100				
23,90	28,09	TSTS-CB2-08 TSTS000181				

INTERLOCKING DETACHABLE CUTTING HEADS

allow you to install a new head in minutes without removing the shaft from the machine. Once the tool reaches its established re-sharpen point, simply retract the tool from the part, unscrew and remove the head, replace it with a re-ground head and return to the previous drilling position and continue drilling.

Additionally, when the drill reaches its maximum depth an extension can easily be added resulting in unlimited drill depths. This is the optimal method of drilling and maintaining concentricity throughout the hole; you are now able to drill hole depths far exceeding the stroke of your machine.

THE BENEFITS

- * Minimize downtime
- * The ability to drill depths far exceeding the stroke of your machine.
- * Ease of re-sharpening heads without the cumbersome process of removing the entire tool.
 - * Standard head sizes in stock for same day delivery
 - * Re-sharpening and re-tipping programs available
 - * Ergonomic user-friendly design

INTERLOCK HEADS

Dia.	PN	Dia.	PN
.6250"	100584	1.2500"	100597
.7500"	100585	1.2656"	100598
.8125"	100586	1.3125"	100599
.8750"	100587	1.3750"	100600
.9062"	100588	1.4375"	100601
.9375"	100589	1.5000"	100602
.9687"	100590	1.6250"	100603
.9844"	100591	1.7500"	100604
1.000"	100592	1.8125"	100605
1.0625"	100593	1.8750"	100606
1.1250"	100594	1.9375"	100607
1.1562"	100595	2.0000"	100608
1.1875"	100596		

DIAMETER RANGE

Drive#	MIN	MAX
2	.6250"	.7400"
3A	.7410"	.8420"
3B	.8430"	.9290"
4	.9300"	1.1180"
5A	1.1190"	1.2170"
5B	1.2180"	1.3670"
6	1.3680"	1.5000"
6A	1.5010"	1.6800"
6B	1.6810"	1.8990"
7	1.9000"	2.0620"
7A	2.0630"	2.1250"
7B	2.1260"	2.4140"
8	2.4150"	3.0000"

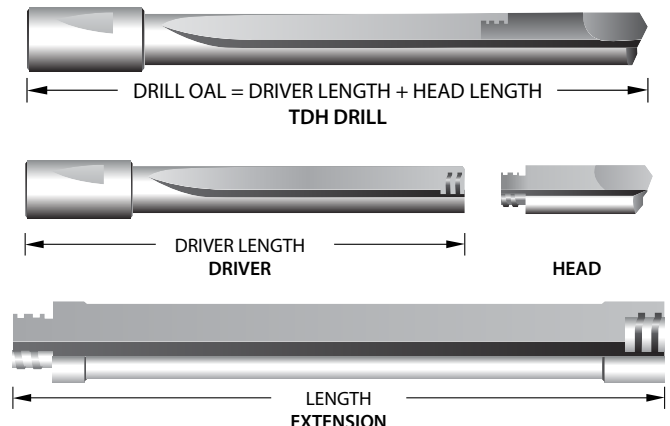
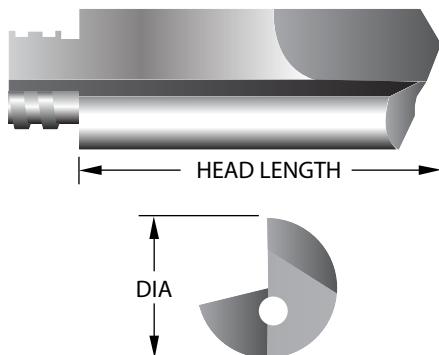

ELDO-LOC® DETACHABLE TIPS

Similar to its counterpart, the Detachable Style Head, the Eldo-Loc continues to support customers who have the Eldo-Loc style female driver. This allows for easier handling of extra long or large diameter gundrills. This is an optional method available for gundrills from .6250" (15.875mm) to 2.3750" (60.325mm) in diameter.

Additionally, when the drill reaches its maximum depth an extension can easily be added resulting in unlimited drill depths. This is the optimal method of drilling and maintaining concentricity throughout the hole; you are now able to drill hole depths far exceeding the stroke of your machine.

THE BENEFITS

- * Minimize downtime
- * The ability to drill depths far exceeding the stroke of your machine.
- * Ease of re-sharpening heads without the cumbersome process of removing the entire tool.
 - * Standard head sizes in stock for same day delivery
 - * Re-sharpening and re-tipping programs available
 - * Ergonomic user-friendly design

MALE/FEMALE ELDO-LOKS

ELDO-LOC® HEADS

Dia.	PN	Dia.	PN
1.2500"	100681	1.6250"	100616
1.3125"	100609	1.6875"	100617
1.3437"	100610	1.7500"	100618
1.3750"	100611	1.8125"	100619
1.4375"	100612	1.8750"	100620
1.4844"	100613	1.9375"	100621
1.5000"	100614	2.0000"	100622
1.5625"	100615		

Tip Size Range	Driver	Tip Size Range	Driver
.6200-.6399	#1	.9200-.9399	#17
.6400-.6499	#2	.9400-.9599	#18
.6500-.6599	#3	.9600-.9799	#19
.6600-.6799	#4	.9800-1.0049	#20
.6800-.6999	#5	1.0050-1.0449	#21
.7000-.7199	#6	1.0450-1.1049	#22
.7200-.7399	#7	1.1050-1.1749	#23
.7400-.7599	#8	1.1750-1.2199	#24
.7600-.7799	#9	1.2200-1.2949	#25
.7800-.7999	#10	1.2950-1.3449	#26
.8000-.8199	#11	1.3450-1.4799	#27
.8200-.8399	#12	1.4800-1.5849	#28
.8400-.8599	#13	1.5850-1.7049	#29
.8600-.8799	#14	1.7050-1.8449	#30
.8800-.8999	#15	1.8450-1.9649	#31
.9000-.9199	#16	1.9650-2.0000	#32

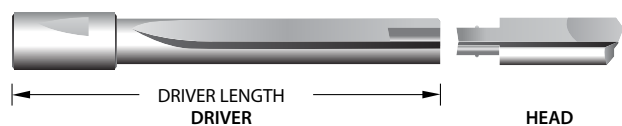
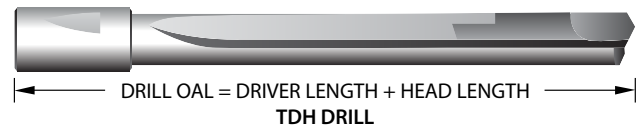
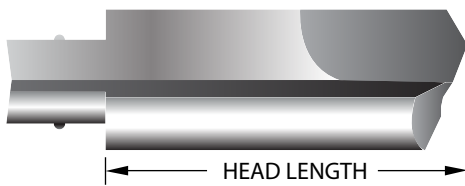

RECONDITIONING TOOLS “CRADLE TO GRAVE”

Our goal is to monitor your hole-making process ideally from “Cradle to Grave” Once the initial tool is engineered and the process is stable our staff can evaluate how the tool is performing by the wear characteristics exhibited on the tool when it is returned for re-sharpening. Throughout the life of the tool we can determine when it’s time to re-tip, re-straighten, change re-sharpen intervals, or alter running conditions. These scenarios may be due to material variances, types of coolant being used, filtration, or the need for coating

Re-Sharpener

We provide a re-sharpening service which enables our customers to return their used drills and have them re-ground to factory specifications and returned in 24 – 48 hours. By doing so, our customers realize cost savings by maximizing the number of regrinds before re-tipping and allowing our expert staff to observe the wear characteristics and make recommendations for improvements in their processes. Standard & Special grinds: N8, N4, N73, N126, facet, chip-breakers, corner & full spherical radius, step grinds, etc. (See catalog page 11)

This service can be performed on all competitors’ tools as well

Re-Tipping

When a tool reaches the point when it can no longer be used because it’s been re-sharpened to its limit, it’s chipped, or misused, etc., it can be sent back for re-tipping. Once a tool is re-tipped, it performs exactly as a new tool. This process extends cost savings to our customers as much as 20% of the cost of a new tool.

This service can be performed on all competitors’ tools.

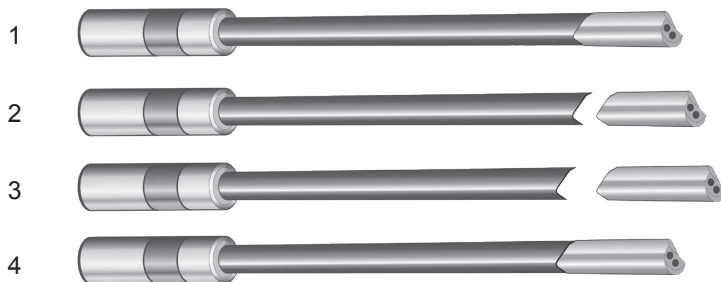

1. Condition upon delivery
2. Remove used carbide head
3. Fit new head
4. Reconditioned tool

Re-Straightening

One of the most critical features of the tools performance is it’s straightness from the driver to the tip. Throughout the life of a tool it’s subjected to numerous removals from the machine, re-sharpening, re-installations, crashes, miss-handling, etc. These scenarios will contribute to inconsistency in hole -size, excessive run-out and premature tool wear. Most times as long as a tool isn’t kinked, it can be re-straightened at a fraction of the cost of a new tool.

This service can be performed on all competitors’ tools

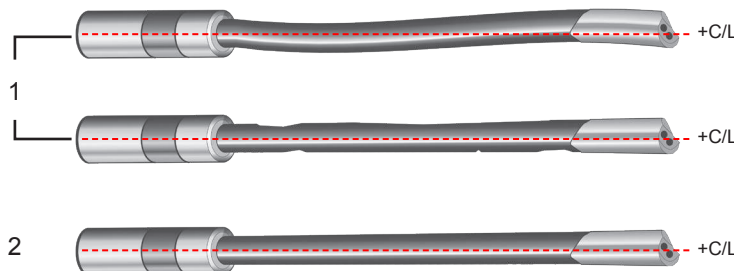

1. Bent
2. Restraightened to factory specs

In-House Consulting

When you’ve exhausted every effort and gone down every avenue to eliminate a hole making problem or you’re looking for some cost savings, it might be time to call in a professional. Our applications specialists each have over 30 years experience specifically in the gundrilling field. They will visit your facility, evaluate your hole making process, identify areas of concern, and make recommendations for enhancements to re-stabilize your process and most importantly show where cost savings may be captured.

Call us for a quote.

GUN BARREL TOOLING

• 1. Pull Bore Reamer



Pull Bore Reaming is an essential process when manufacturing rifle or smooth bore barrels. Once the bore of the barrel blank is gun-drilled, the Pull Bore Reamer is used to enlarge the hole to eliminate any imperfections that can be left inside the bore. Stock removal is usually .003"-.004" per side. This carbide reamer is manufactured to + - .0001" which gives this rotary cutting tool precision accuracy to establish size control while maintaining an excellent surface finish. The reamer is then mounted to a seamless heat treated tube which allows for any desired length to be pulled back through the barrel. High pressure coolant flows inside the tube through the oil channels and over the flutes of the reamer so that no cutting chips interfere with the surface finish of the bore.

Reamers are available in TIN or TIALN coatings.

• 2. Rifling Buttons

Rifling Buttons are Precision Carbide Tools for forming the rifling grooves and resizing the bore in gun barrels. Sizes range from 14 caliber Rifles to 10 gauge rifled shotgun barrels and can be ground with any helical twist right or left-handed. They are available in rifle only, bore only, or combination style. The Buttons are either pushed or pulled through the barrel depending on the type of equipment you have available. We also recommend all rifle buttons be coated with either (TIN) Titanium-Nitrate or a (TIALN / Futura Nano) Titanium Aluminum Nitrate coating. This will improve your tool life and increase barrel finish by keeping the material from cold welding to the buttons.



All these buttons are made to your specifications or we can determine the size of the button based on material, hardness and wall thickness of the blank. To achieve the correct size button all these variables must be determined for the expansion and contraction during the buttoning process. If you plan to stress-relieve the barrel after rifling, this also needs to be evaluated and calculated in the equation.

Once you determine the style of Rifle Button you wish to use you need to determine the exact size of the Rifling and Bore you wish to establish in the barrel. You need to first start with a good straight gun drill hole approximately .006"-.008" smaller than your Bore size. Then pass a reamer through the barrel to establish your Bore size to remove any surface imperfections and control the inside diameter of the barrel from one end to the other.

• 2. Rifling Buttons (cont.)

Then you are ready to push or pull your button through the barrel. Utilizing a good pressure lube is required to achieve good results. The process is very fast, approximately 40"-60" per minute. A combination button which consists of a Rifling button and a Bore button will both swage the lands in the barrel and resize the bore section in one pass.

• Hammer Forging Mandrels

Another means of producing rifling in barrels is by **Hammer Forging Rifling Mandrels**. We manufacture these very precise tools in high-impact carbide. The carbide mandrel has the entire depth rifling pattern ground into its surface to reflect the exact interior of the barrel. Very precise tolerances are maintained to manufacture this tool.

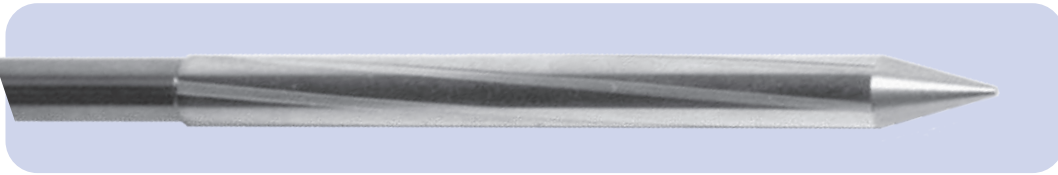

• Rifle/Bore Gages

In order to measure the inside of the rifled barrel you need to use **Rifle and Bore Air Gage** probes.

We manufacture these in carbide to the SAMMI barrel specifications to give you the correct sizes throughout the barrel. These probes are functional with the use of an Air Column and Master Setting Rings which will give you precise measurements throughout your barrel



• Gun Drilling System



This custom system for resharpener your gundrills in-house, will definitely save you time and money.

- Fitted with either the Model B or Facet Grind Gundrill Sharpening Fixture
- Gundrill capacity:
 - Model B = 0.075 - 1.0625 inches (1.91 - 27.0 mm)
 - Facet Grind = 0.156 - 1.250 inches (4 - 32 mm)
- X-axis & Y-axis slides, head adjustable in Z-axis
- Digital Readout for both X-axis and Y-axis
- Fitted with diamond cup grinding wheel and dust collection system
- Video inspection microscope with Led display monitor, up to 40:1 magnification

The Facet Gundrill Sharpening Fixture •

Capacity:
0.156" - 1.25" (4 mm - 32 mm)

This manual regrind fixture provides a fast and easy method of resharpener gun drills with the popular facet style grind. Drills are positioned and ground without the need of expensive bushings or collets. The universal nature of the fixture allows standard or custom regrinds.

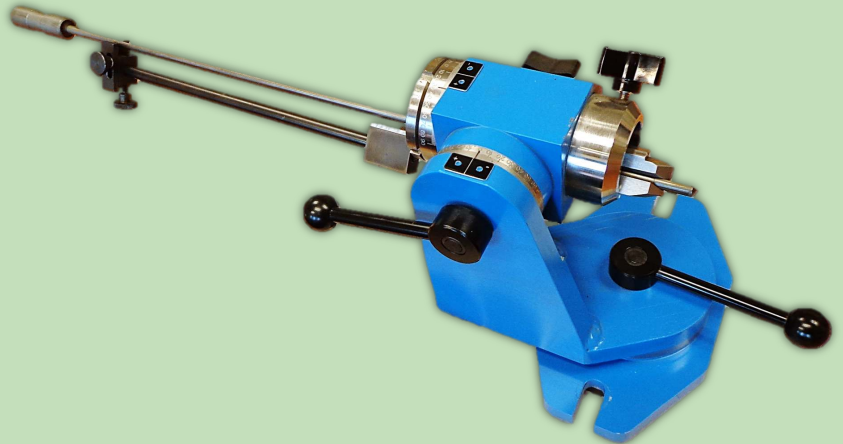

Part #109245

The Gun Drill Regrinding Fixture of Three Elements:

- 1). **The Workhead** with clamping device to hold either a single flute gun drills in position.
- 2). **A Scale**, graduated in degrees, to allow the drill to be aligned in the vertical plane. This scale is mounted on the vertical member of the fixture that holds the workhead.
- 3). **A Scale** mounted on the diamond - shaped base of the fixture to allow the drill to be angled in the horizontal plane. This scale is graduated in degrees.

Both scales have locking levers to maintain vertical and horizontal positioning, and when used together allow compound angles to be ground on the nose of the drill mounted in the workhead.

The fixture is normally used on a tool and cutter grinder equipped with a 11V9 or 11A2 style diamond wheel (220 - 320 grit). Some may chose a metal or plated bond wheel with concentric roughing and finishing faces, the roughing face having a coarser grit than the finishing faces. The spindle of the grinding wheel will start at 90° to the table slideway.

Model "B" Sharpening Fixture •

The traditional Model B Gundrill Sharpening Fixture is the most widely used in the world. The B Fixture is used to sharpen single flute gundrills from .055" (1.39mm) to 1.062" (26.9mm) in diameter. The heavy duty construction of this unit assures repetitive grinding quality, lowers the cost per hole, eliminates down time, ends inefficiency and reduces costly rejects. The fixture mounts easily on conventional tool and cutter or surface grinders as well as our Universal Bench Top Grinder. Any shop personnel can quickly and accurately reproduce the required nose geometry without carbide and diamond wheel waste. Once the combination of angles and clearances are specified, the operation is routine.

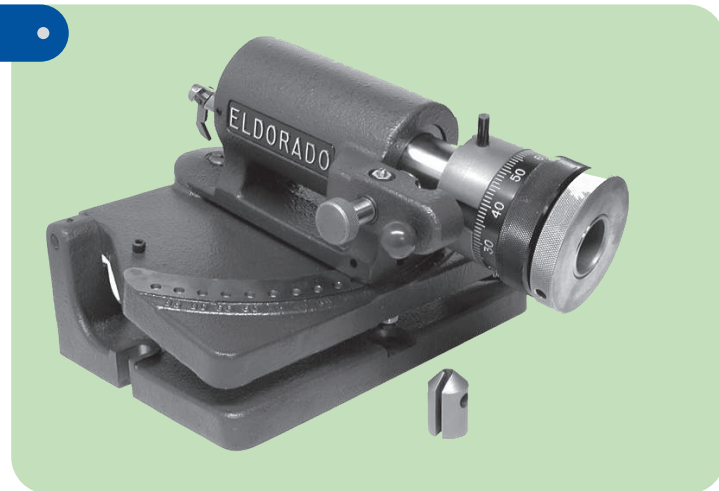

Part #107245

Collet Inserts for Eldorado Model "B" Gundrill Sharpening Fixtures
Gundrill Sizes .0750 - .7500

CALL FOR PRICING

Part No.	Collet Insert Size	For Drills		Part No.	Collet Insert Size	For Drills		Part No.	Collet Insert Size	For Drills	
		From	To			From	To			From	To
107270	.0781	.0750	.0781	107303	.2500	.2541	.2500	107335	.5000	.4921	.5000
107271	.0830	.0782	.0830	107303	.2580	.2501	.2580	107336	.5080	.5001	.5080
107272	.0880	.0831	.0880	107305	.2656	.2581	.2656	107337	.5156	.5081	.5156
107273	.0937	.0881	.0937	107306	.2740	.2657	.2740	107338	.5230	.5157	.5230
107274	.0990	.0938	.0990	107307	.2812	.2741	.2812	107339	.5312	.5231	.5312
107275	.1040	.0991	.1040	107308	.2890	.2813	.2890	107340	.5390	.5312	.5390
107276	.1094	.1041	.1094	107309	.2969	.2891	.2969	107341	.5469	.5391	.5469
107277	.1150	.1095	.1150	107310	.3050	.2970	.3050	107342	.5550	.5470	.5550
107278	.1200	.1151	.1200	107311	.3125	.3051	.3125	107343	.5625	.5551	.5625
107279	.1250	.1201	.1250	107312	.3200	.3126	.3200	107344	.5700	.5625	.5700
107280	.1300	.1251	.1300	107313	.3281	.3201	.3281	107345	.5781	.5701	.5781
107281	.1350	.1301	.1350	107314	.3360	.3282	.3360	107346	.5860	.5782	.5860
107282	.1406	.1351	.1406	107315	.3437	.3361	.3437	107347	.5937	.5861	.5937
107283	.1460	.1407	.1460	107316	.3520	.3438	.3520	107348	.6020	.5938	.6020
107284	.1510	.1461	.1510	107317	.3594	.3521	.3594	107349	.6094	.6021	.6094
107285	.1562	.1511	.1562	107318	.3680	.3595	.3680	107350	.6170	.6095	.6170
107286	.1610	.1563	.1610	107319	.3750	.3681	.3750	107351	.6250	.6171	.6250
107287	.1660	.1611	.1660	107320	.3830	.3851	.3830	107352	.6330	.6251	.6330
107288	.1719	.1661	.1719	107321	.3906	.3831	.3906	107353	.6406	.6331	.6406
107289	.1770	.1720	.1770	107322	.3980	.3907	.3980	107354	.6480	.6407	.6480
107290	.1820	.1771	.1820	107323	.4062	.3981	.4062	107355	.6562	.6481	.6562
107291	.1875	.1821	.1875	107324	.4140	.4063	.4140	107356	.6640	.6563	.6640
107292	.1930	.1876	.1930	107325	.4219	.4141	.4219	107357	.6719	.6641	.6719
107293	.1980	.1931	.1980	107326	.4300	.4220	.4300	107358	.6800	.6720	.6800
107294	.2031	.1981	.2031	107327	.4375	.4301	.4375	107359	.6875	.6801	.6875
107295	.2080	.2032	.2080	107328	.4450	.4376	.4450	107360	.6950	.6876	.6950
107296	.2130	.2081	.2130	107329	.4531	.4451	.4531	107361	.7031	.6951	.7031
107297	.2187	.2131	.2187	107330	.4610	.4532	.4610	107362	.7110	.7032	.7110
107298	.2240	.2188	.2240	107331	.4687	.4611	.4687	107363	.7187	.7111	.7187
107299	.2290	.2241	.2290	107332	.4760	.4688	.4760	107364	.7270	.7188	.7270
107300	.2344	.2291	.2344	107333	.4844	.4761	.4844	107365	.7344	.7271	.7344
107301	.2400	.2345	.2400	107334	.4920	.4845	.4920	107366	.7420	.7345	.7420
107302.245	.2450	.2401	.2450					107367	.7500	.7421	.7500

Collet Inserts for Eldorado Model "B" Gundrill Sharpening Fixtures
Gundrill Sizes .7501-1- 1.0625

Part No.	Collet Insert Size	For Drills		Part No.	Collet Insert Size	For Drills	
		From	To			From	To
107406	.7580	.7501	.7580	107426	.9140	.9063	.9140
107407	.7656	.7581	.7656	107427	.9219	.9141	.9219
107408	.7730	.7657	.7730	107428	.9297	.9220	.9297
107409	.7812	.7731	.7812	107429	.9375	.9298	.9375
107410	.7890	.7813	.7890	107430	.9453	.9376	.9453
107411	.7969	.7891	.7969	107431	.9531	.9454	.9531
107412	.8050	.7970	.8050	107432	.9609	.9532	.9609
107413	.8125	.8051	.8125	107433	.9688	.9610	.9688
107414	.8200	.8126	.8200	107434	.9766	.9689	.9766
107415	.8281	.8201	.8281	107432	.9844	.9767	.9844
107416	.8360	.8282	.8360	107436	.9922	.9845	.9922
107417	.8437	.8361	.8437	107437	1.0000	.9923	1.0000
107418	.8520	.8438	.8520	107438	1.0078	1.0001	1.0078
107419	.8594	.8521	.8594	107439	1.0156	1.0079	1.0156
107420	.8670	.8595	.8670	107440	1.0234	1.0157	1.0234
107421	.8750	.8671	.8750	107441	1.0312	1.0235	1.0312
107422	.8828	.8751	.8828	107442	1.0390	1.0313	1.0390
107423	.8906	.8829	.8906	107443	1.0468	1.0391	1.0468
107424	.8984	.8907	.8984	107444	1.0546	1.0469	1.0546
107425	.9062	.8985	.9062	107445	1.0625	1.0547	1.0625

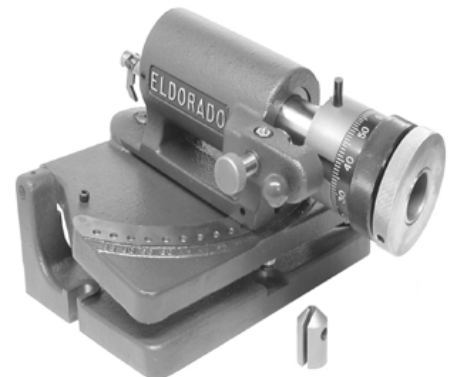

DRIVER STYLE OVERVIEW

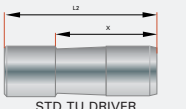
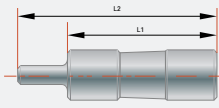
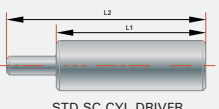
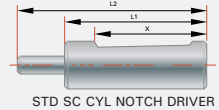
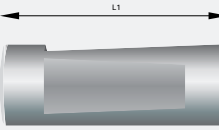
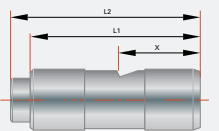
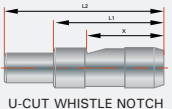
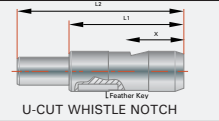
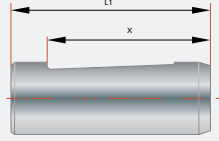
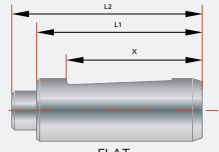
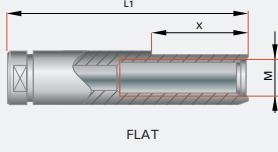
Part#	Dia.	Length	DESCRIPTION	L1	L2	X	TAP	
DRAT	0.500" [12.7mm]	1.500" [38.1mm]	 <p style="text-align: center;">STD TU DRIVER</p>		1.500" [38.1mm]	1.000" [25.4mm]		
DRBT	0.7500" [19.05mm]	2.750" [69.8mm]				2.750" [69.8mm]	1.748" [44.4mm]	3/8 X 24
DRAS	0.500" [12.7mm]	2.000" [50.8mm]	 <p style="text-align: center;">STD SC TU DRIVER</p>	1.500" [38.1mm]	2.000" [50.8mm]			
DRJC	0.2362" [6mm]	1.967" [49.9mm]	 <p style="text-align: center;">STD SC CYL DRIVER</p>	1.500" [38.1mm]	1.967" [49.9mm]			
DRAC	0.500" [12.7mm]	2.000" [50.8mm]			1.500" [38.1mm]	2.000" [50.8mm]		
DRSJ	.2362" [6mm]	1.967" [49.9mm]	 <p style="text-align: center;">STD SC CYL NOTCH DRIVER</p>	1.417" [36mm]	1.967" [49.9mm]	.984" [30.0mm]		
DRCF	1.000" [25.4mm]	2.750" [69.8mm]	 <p style="text-align: center;">STD 2TF DRIVER</p>	2.750" [69.8mm]				
DRDF	1.250" [31.75mm]	2.750" [69.8mm]			2.750" [69.8mm]			
DREF	1.500" [38.1mm]	2.750" [69.8mm]			2.750" [69.8mm]			
DRFF	2.000" [50.8mm]	2.750" [69.8mm]			2.750" [69.8mm]			
DRJB	0.3937" [10.0mm]	1.575" [40.0mm]	 <p style="text-align: center;">U-CUT WHISTLE NOTCH</p>	1.575" [40.0mm]	1.811" [46.0mm]	0.957" [24.3mm]		
DRLB	0.6299" [16.0mm]	1.969" [50.0mm]			1.969" [50.0mm]	2.283" [58.0mm]	1.870" [47.5mm]	
DRHB	0.9843" [25.0mm]	2.756" [70.0mm]			2.756" [70.0mm]	3.071" [78.0mm]	1.339" [34.0mm]	
DRJA	0.3937" [10.0mm]	1.575" [40.0mm]	 <p style="text-align: center;">U-CUT WHISTLE NOTCH</p>	1.654" [42.0mm]	2.165" [55.0mm]	0.957" [24.3mm]		
DRLA	0.6299" [16.0mm]	1.969" [50.0mm]			2.047" [52.0mm]	2.953" [75.0mm]	1.870" [47.5mm]	
DRHD	0.9843" [25.0mm]	2.756" [70.0mm]	 <p style="text-align: center;">U-CUT WHISTLE NOTCH Feather Key</p>	2.835" [72.0mm]	4.134" [105.0mm]	1.339" [34.0mm]		
DRCG	1.000" [25.4mm]	2.748" [69.8mm]	 <p style="text-align: center;">FLAT</p>	2.748" [69.8mm]		2.248" [57.1mm]		
DRDG	1.250" [31.75mm]	2.748" [69.8mm]			2.748" [69.8mm]		2.248" [57.1mm]	
DREG	1.500" [38.1mm]	2.748" [69.8mm]			2.748" [69.8mm]		2.248" [57.1mm]	
DRCH	1.000" [25.4mm]	2.748" [69.8mm]	 <p style="text-align: center;">FLAT</p>	2.748" [69.8mm]	4.134" [105.0mm]	2.248" [57.1mm]		
DRDH	1.250" [31.75mm]	2.748" [69.8mm]			2.748" [69.8mm]	3.397" [100.0mm]	2.248" [57.1mm]	
DREH	1.500" [38.1mm]	2.748" [69.8mm]			2.748" [69.8mm]	3.397" [100.0mm]	2.248" [57.1mm]	
DRJI	0.3937" [10.0mm]	2.677" [68.0mm]	 <p style="text-align: center;">FLAT</p>	2.677" [68.0mm]		1.380" [35.0mm]	M6 X 0.5	
DRLI	0.6299" [16.0mm]	3.543" [90.0mm]			3.543" [90.0mm]		1.457" [37.0mm]	M10 X 1
DRHI	0.9843" [25.0mm]	4.409" [112.0mm]			4.409" [112.0mm]		1.772" [45.0mm]	M16 X 1.5
DRJE	0.3937" [10.0mm]	2.677" [68.0mm]			2.677" [68.0mm]	3.189" [81.0mm]	1.378" [35.0mm]	M6 X 0.5
DRLE	0.6299" [16.0mm]	3.543" [90.0mm]			3.543" [90.0mm]	4.331" [110.0mm]	1.457" [37.0mm]	M10 X 1
DRHE	0.9843" [25.0mm]	4.409" [112.0mm]		4.409" [112.0mm]	5.591" [142.0mm]	1.772" [45.0mm]	M16 X 1.5	

DRIVER STYLE OVERVIEW

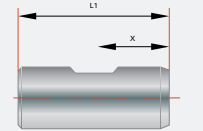
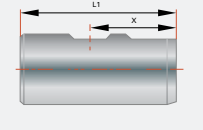
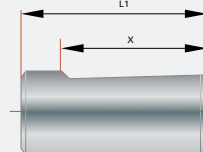
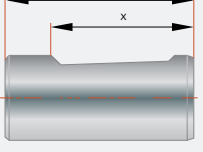
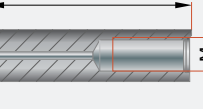
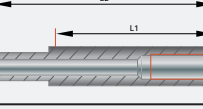
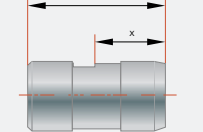
Part#	Dia.	Length	DESCRIPTION	L1	L2	X	TAP
DRJP	0.3937" [10.0mm]	1.575" [40.0mm]	 CYL	1.575" [40.0mm]			
DRGP	0.4724" [12.0mm]	1.772" [45.0mm]		1.772" [45.0mm]			
DRLP	0.6299" [16.0mm]	1.890" [48.0mm]		1.890" [48.0mm]			
DRIP	0.7874" [20.0mm]	1.969" [50.0mm]		1.969" [50.0mm]			
DRHP	0.9843" [25.0mm]	2.205" [56.0mm]		2.205" [56.0mm]			
DRKP	1.2598" [32.0mm]	2.362" [60.0mm]		2.362" [60.0mm]			
DRJW	0.3937" [10.0mm]	1.575" [40.0mm]	 1 WELDON FLAT	1.575" [40.0mm]		0.787 [20.0mm]	
DRGW	0.4724" [12.0mm]	1.772" [45.0mm]		1.772" [45.0mm]		0.886" [22.5mm]	
DRLW	0.6299" [16.0mm]	1.890" [48.0mm]		1.890" [48.0mm]		0.945 [24.0mm]	
DRJX	0.3937" [10.0mm]	2.205" [56.0mm]	 WELDON FLAT	2.205" [56.0mm]		1.260" [32.0mm]	
DRGX	0.4724" [12.0mm]	2.362" [60.0mm]		2.362" [60.0mm]		1.417" [36.0mm]	
DRLX	0.6299" [16.0mm]	2.756" [70.0mm]		2.756" [70.0mm]		1.575 [40.0mm]	
DRJY	0.3937" [10.0mm]	1.575" [40.0mm]	 1 TF	1.575" [40.0mm]		1.102" [28.0mm]	
DRGY	0.4724" [12.0mm]	1.772" [45.0mm]		1.772" [45.0mm]		1.299" [33.0mm]	
DRLY	0.6299" [16.0mm]	1.890" [48.0mm]		1.890" [48.0mm]		1.417" [36.0mm]	
DRHY	0.9843" [25.0mm]	2.205" [56.0mm]		2.205" [56.0mm]		1.732" [44.0mm]	
DRKY	1.2598" [32.0mm]	2.362" [60.0mm]		2.362" [60.0mm]		1.890" [48.0mm]	
DRJZ	0.3937" [10.0mm]	1.575" [40.0mm]	 1 TF	1.575" [40.0mm]		1.102" [28.0mm]	
DRGZ	0.4724" [12.0mm]	1.772" [45.0mm]		1.772" [45.0mm]		1.299" [33.0mm]	
DRLZ	0.6299" [16.0mm]	1.890" [48.0mm]		1.890" [48.0mm]		1.417" [36.0mm]	
DRHZ	0.9843" [25.0mm]	2.205" [56.0mm]		2.205" [56.0mm]		1.732" [44.0mm]	
DRJU	0.3937" [10.0mm]	2.362" [60.0mm]	 M	2.362" [60.0mm]			M6 X 0.5"
DRLU	0.6299" [16.0mm]	3.150" [80.0mm]		3.150" [80.0mm]			M10 X 1.0"
DRHU	0.9843" [25.0mm]	3.937" [100.0mm]		3.937" [100.0mm]			M16 X 1.5"
DRLV	0.6299" [16.0mm]	3.150" [80.0mm]	 M	3.150" [80.0mm]	3.937" [100.0mm]		M10 X 1.0"
DRHV	0.9843" [25.0mm]	3.937" [100.0mm]		3.937" [100.0mm]	5.512" [140.0mm]		M16 X 1.5"
DRLM	0.6299" [16.0mm]	1.575" [50.0mm]	 X	1.575" [50.0mm]		0.61" [15.494mm]	
DRHM	0.9843" [25.0mm]	1.969" [50.0mm]		1.969" [50.0mm]		1.004" [25.5mm]	
DRRM	1.378" [35.0mm]	2.362" [60.0mm]		2.362" [60.0mm]		1.161" [25.489mm]	

Chip Deflectors

Chip Deflectors stop metal chips and cutting oil from exiting the back of the chip box. They provide sealing only and no drill support. They are used on gun drill machines with short rigid drills when whipping is not a problem. They are also used in front of a Drill Guide or a SnapGuide® to extend bushing and bearing life. Chip Deflectors feature a hardened-steel face bonded to a flexible polymer backing to provide perfect sealing on the drill and long life.

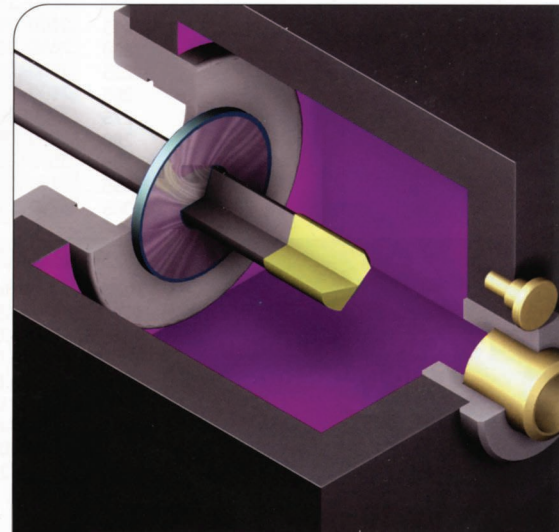
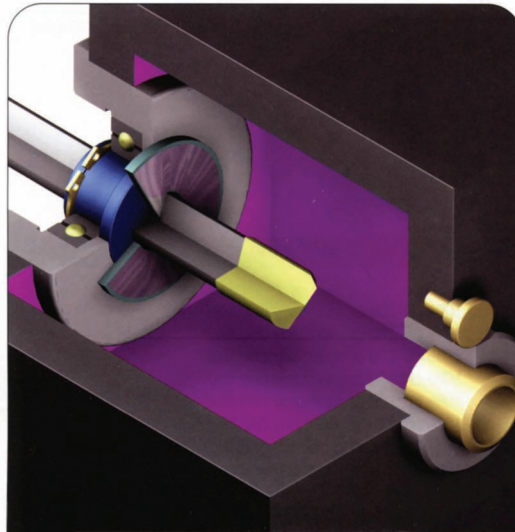

Drill Guides

Flexible plastic Drill Guide bushings stop drill whipping and seal the chip box by stretching over the carbide drill tip and contracting onto the steel drill body. They are typically mounted in a bearing and rotate with the drill. This is our first and oldest product and is still used by many customers to maximize penetration rates, accuracy, and stop vibration. These bushings perform the same function as the SnapGuide®. Our signature Blue Bushings® guarantee you top quality.

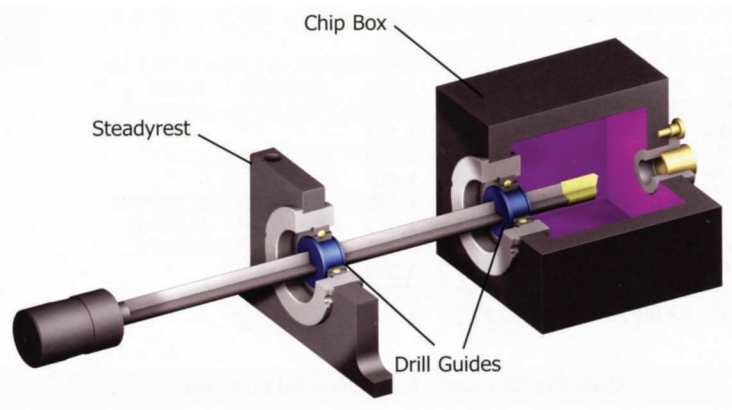
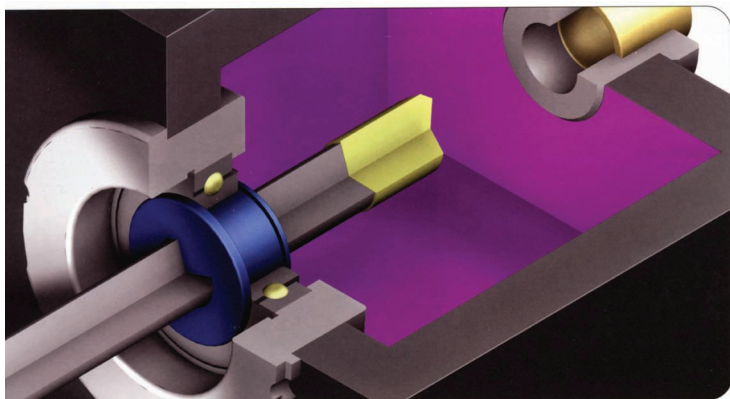

GUN DRILL BUSHINGS

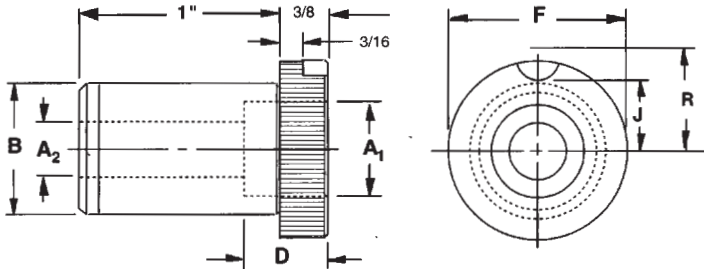

Liners - Type GDL

DMET Gun Drill Liners are designed to be used with the replaceable inserts indicated in the table below. All type GDL Bushings are ground concentric within .0002" T.I.R. The heads are undercut and ground square with outside diameters so the liner will sit flat against the chip box.

Part Number	Description	A ₁ +.0002 -.0000	A ₂ ±.005	B O.D. Size		D	Head Dimensions			Lockscrew	Insert Used
				Nominal	Actual		F	J	R		
A51210	GDL-64-16	.2045	.125	1"	1.0000 .9998	7/16	1-27/64	19/32	59/64	2A-LS	GDI-13-8
A51212		.2515	.156								GDI-16-8
A51214		.3140	.218								GDI-20-8
A51216		.5016	.406								GDI-32-8
A51218		.7517	.625								GDI-48-8
A51240	GDL-88-16	.2045	.125	1-3/8	1.3750 1.3748	7/16	1-51/64	25/32	1-7/64	2A-LS	GDI-13-8
A51242		.2515	.156								GDI-16-8
A51244		.3140	.218								GDI-20-8
A51246		.5016	.406								GDI-32-8
A51248		.7517	.625								GDI-48-8
A51250		1.0017	.875			11/16	1-51/64	25/32	1-7/64	2A-LS	GDI-64-12

Inserts - Type GDI

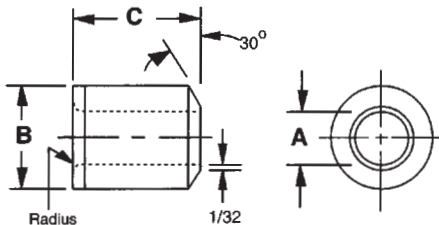

DMET Gun Drill Inserts are manufactured from thru-hardened tool steel and heat treated to 62-64 RC for longer life. The I.D., O.D., and face of GDI Bushings are ground concentric and square within .0002" T.I.R.

Inserts are stocked in standard drill sizes only. Special I.D. sizes and special materials (i.e. Carbide or Titanium Nitride coating) are available to meet your requirements.

Description	A I.D. Range +.0002 / -.0000	B O.D. Size		C Length
		Nominal	Actual	
GDI-13-8	5/64 - #39 (.0781) (.0995)	13/64	.2047 .2044	1/2
GDI-16-8	#38 - 9/64 (.1015) (.1406)	1/4	.2517 .2514	1/2
GDI-20-8	#27 - #10 (.1440) (.1935)	5/16	.3142 .3139	1/2
GDI-32-8	13/64 - O (.2031) (.3160)	1/2	.5018 .5015	1/2
GDI-48-8	P - 17/32 (.3230) (.5312)	3/4	.7519 .7516	1/2
GDI-64-12	9/16 - 3/4 (.5625) (.7500)	1"	1.0019 1.0016	3/4

CHIP DEFLECTORS

Same Day Shipment

Chip Deflectors stop metal chips and cutting oil from exiting the back of the chip box. They provide sealing only and no drill support. They are used on gun drill machines on short rigid drills when whipping is not a problem. They are also used in front of a Drill Guide or a SnapGuide® to extend bushing and bearing life. Chip Deflectors feature a hardened steel face bonded to a flexible polymer backing to provide perfect sealing on the drill and long life.



Part #	Drill Range	Part #	Drill Range	Part #	Drill Range
070	.0781-.0831	315	.3300-.3399	960	.9800-1.0049
075	.0832-.0882	325	.3400-.3499	980	1.0050-1.0449
080	.0883-.0933	335	.3500-.3599	1020	1.0450-1.1049
085	.0934-.0984	345	.3600-.3699	1080	1.1050-1.1749
090	.0985-.1035	355	.3700-.3799	1150	1.1750-1.2199
095	.1036-.1086	365	.3800-.3879	1195	1.2200-1.2749
100	.1087-.1137	370	.3880-.3929	1250	1.2750-1.3449
105	.1138-.1188	375	.3930-.4029	1320	1.3450-1.4799
110	.1189-.1239	385	.4030-.4129	1455	1.4800-1.5849
115	.1240-.1295	400	.4130-.4279	1560	1.5850-1.7049
120	.1296-.1350	410	.4280-.4329	1680	1.7050-1.8449
125	.1351-.1405	415	.4330-.4379	1820	1.8450-1.9649
130	.1406-.1458	420	.4380-.4479	1940	1.9650-2.0000
135	.1459-.1510	430	.4480-.4629		
140	.1511-.1561	445	.4630-.4779		
145	.1562-.1614	460	.4780-.4949		
150	.1615-.1666	475	.4950-.5099		
155	.1667-.1718	490	.5100-.5249		
160	.1719-.1771	505	.5250-.5399		
165	.1772-.1823	520	.5400-.5549		
170	.1824-.1874	535	.5550-.5649		
175	.1875-.1949	545	.5650-.5799		
180	.1950-.1999	560	.5800-.5899		
185	.2000-.2049	570	.5900-.5999		
190	.2050-.2099	580	.6000-.6199		
195	.2100-.2149	600	.6200-.6399		
200	.2150-.2199	620	.6400-.6499		
205	.2200-.2249	630	.6500-.6599		
210	.2250-.2299	640	.6600-.6799		
215	.2300-.2349	660	.6800-.6999		
220	.2350-.2399	680	.7000-.7199		
225	.2400-.2449	700	.7200-.7399		
230	.2450-.2499	720	.7400-.7599		
235	.2500-.2549	740	.7600-.7799		
240	.2550-.2599	760	.7800-.7999		
245	.2600-.2649	780	.8000-.8199		
250	.2650-.2699	800	.8200-.8399		
255	.2700-.2799	820	.8400-.8599		
265	.2800-.2899	840	.8600-.8799		
275	.2900-.2949	860	.8800-.8999		
280	.2950-.2999	880	.9000-.9199		
285	.3000-.3099	900	.9200-.9399		
295	.3100-.3199	920	.9400-.9599		
305	.3200-.3299	940	.9600-.9799		

Part #	Pricing	-	6pcs Minimum Order
070-110	\$6.00 each		
115-235	\$6.00 each		
240-355	\$7.00 each		
365-600	\$8.00 each		
620-720	\$9.00 each		
740-1195	\$10.00 each		
1250-1680	\$12.00 each		
1820-1940	\$14.00 each		

DRILL GUIDE PARTS

Same Day Shipment

Bushing ID	Part #	Drill Range	Bearing ID	Bearing OD	Bushing ID	Part #	Drill Range	Bearing ID	Bearing OD
.070	A100	<=.0831	.315	.9449	.781	E140	.800-.8199	"	"
.080	A110	.0832-.0933	"	"	.796	E150	.820-.8399	"	"
.090	A120	.0934-.1035	"	"	.812	E160	.840-.8599	"	"
.105	A130	.1036-.120	"	"	.828	E170	.860-.8699	"	"
.120	A140	.1201-.1329	"	"	.843	E180	.870-.8799	"	"
.130	A150	.133-.1459	"	"	.859	E190	.880-.9199	"	"
.140	A160	.146-.1561	"	"	.875	E200		"	"
.156	A170	.1562-.1823	"	"	.890	E210	.920-.9399	"	"
.171	A180	.1824-.1949	"	"	.906	E220		"	"
.187	A190	.195-.2099	"	"	.921	E230	.940-.9599	1.378	2.8346
.203	B100	.210-.2289	.590	1.378	.937	E240	.960-.9699	"	"
.219	B110	.229-.2499	"	"	.953	E250	.970-.9799	"	"
.237	B120	.250-.2649	"	"	.968	E260	.980-1.0049	"	"
.250	B130	.265-.2799	"	"	1.008	E280	1.045-1.1049	"	"
.263	B140	.280-.2949	"	"	1.073	E290	1.105-1.1699	"	"
.281	B150	.295-.3079	"	"	1.138	E300	1.170-1.219	"	"
.298	B160	.308-.3299	"	"	.965	F100	.980-1.0049	1.772	3.3465
.314	B170	.330-.3399	"	"	.988	F104	1.005-1.0449	"	"
.328	B174	.340-.3599	"	"	1.005	F110	1.045-1.1049	"	"
.343	B180	.360-.3699	"	"	1.028	F114		"	"
.357	B190	.370-.3799	"	"	1.065	F120	1.105-1.1699	"	"
.375	B200	.393-.4059	"	"	1.135	F130	1.170-1.1999	"	"
.390	B210	.406-.4249	"	"	1.145	F134	1.200-1.2349	"	"
.406	C100	.425-.4479	.787	1.8504	1.180	F140	1.235-1.2599	"	"
.429	C110	.448-.4629	"	"	1.235	F150	1.260-1.2999	"	"
.437	C120	.463-.4779	"	"	1.275	F160	1.300-1.3409	"	"
.453	C130	.478-.4909	"	"	1.305	F170	1.3410-1.399	"	"
.468	C140	.491-.5099	"	"	1.335	F180	1.400-1.4439	"	"
.484	C150	.510-.5249	"	"	1.346	F356		"	"
.500	C160	.525-.5399	"	"	1.378	F363		"	"
.509	C170	.540-.5549	"	"	1.365	G090		2.165	3.937
.531	C180	.555-.5649	"	"	1.400	G100	1.444-1.4949	"	"
.546	C190	.565-.5799	"	"	1.440	G110	1.495-1.5032	"	"
.562	C200	.580-.5999	"	"	1.475	G120	1.503-1.5699	"	"
.466	D030	.491-.5099	.984	2.0472	1.545	G130	1.570-1.6899	"	"
.482	D050	.510-.5249	"	"	1.665	G140	1.690-1.7599	"	"
.510	D070	.540-.5549	"	"	1.720	H100	1.760-1.8209	2.559	4.7244
.578	D100	.600-.6199	"	"	1.805	H110	1.821-1.9309	"	"
.593	D110	.620-.6399	"	"	1.925	H120	1.980-2.000	"	"
.609	D120	.640-.6599	"	"	2.035	H130		"	"
.625	D130	.660-.6799	"	"	2.180	4140		"	"
.640	D140		"	"				"	"
.656	D150	.680-.6999	"	"				"	"
.671	D160	.700-.7199	"	"				"	"
.687	D170	.704-.718	"	"				"	"
.703	D180	.720-.7399	"	"				"	"
.718	D190	.740-.7599	"	"				"	"
.703	E090	.720-.7399	1.378	2.8346					
.718	E100	.740-.7599	"	"					
.734	E110	.760-.7799	"	"					
.750	E120	.780-.7899	"	"					
.765	E130	.790-.7999	"	"					

Flexible plastic Drill Guide bushings stop drill whipping and seal the chip box by stretching over the carbide drill tip and contracting onto the steel drill body. They are typically mounted in a bearing and rotate with the drill. This is our first and oldest product and is still used by many customers to maximize penetration rates, accuracy, and stop vibration. These bushings perform the same function as the SnapGuide®. Our signature Blue Bushings® guarantee you top quality.

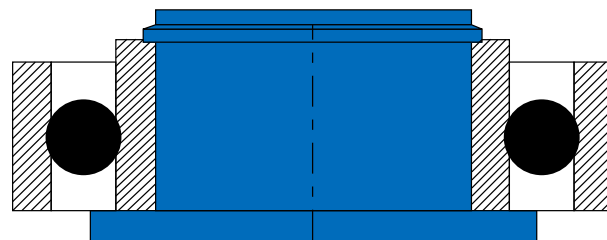



STOCK GUNDRILLS

Size	DMET Part#	Decimal Size (inches)	Metric Size (mm)	Driver (inches)
Kidney Coolant Hole				
5/64"	112758SK	0.0781 x 6	1.984 x 152	.50 x 1.50
	112759SK	0.0781 x 10	1.984 x 254	.50 x 1.50
#46	100534SK	0.0810 x 6	2.057 x 152	.50 x 1.50
	100535SK	0.0810 x 10	2.057 x 254	.50 x 1.50
#45	100006SK	0.0820 x 6	2.083 x 152	.50 x 1.50
	112475SK	0.0820 x 10	2.083 x 254	.50 x 1.50
#44	100007SK	0.0860 x 6	2.184 x 152	.50 x 1.50
	104708SK	0.0860 x 10	2.184 x 254	.50 x 1.50
#43	100008SK	0.0890 x 6	2.261 x 152	.50 x 1.50
	112476SK	0.0890 x 10	2.261 x 254	.50 x 1.50
3/32"	112764SK	0.0937 x 6	2.380 x 152	.50 x 1.50
	112765SK	0.0937 x 10	2.380 x 254	.50 x 1.50
	111110SK	0.0937 x 12	2.380 x 305	.50 x 1.50
	112766SK	0.0937 x 16	2.380 x 406	.50 x 1.50
#41	100536SK	0.0960 x 6	2.438 x 152	.50 x 1.50
	100537SK	0.0960 x 10	2.438 x 254	.50 x 1.50
#40	100538SK	0.0980 x 6	2.489 x 152	.50 x 1.50
	100539SK	0.0980 x 10	2.489 x 254	.50 x 1.50
#39	100540SK	0.0995 x 6	2.527 x 152	.50 x 1.50
	100541SK	0.0995 x 10	2.527 x 254	.50 x 1.50
#38	100017SK	0.1015 x 6	2.578 x 152	.50 x 1.50
	100542SK	0.1015 x 10	2.578 x 254	.50 x 1.50
#37	100019SK	0.1040 x 6	2.642 x 152	.50 x 1.50
	100020SK	0.1040 x 10	2.642 x 254	.50 x 1.50
#36	100021SK	0.1065 x 6	2.705 x 152	.50 x 1.50
	100543SK	0.1065 x 10	2.705 x 254	.50 x 1.50
7/64	112767SK	0.1094 x 6	2.778 x 152	.50 x 1.50
	112768SK	0.1094 x 10	2.778 x 254	.50 x 1.50
	111520SK	0.1094 x 12	2.778 x 305	.50 x 1.50
	112769SK	0.1094 x 16	2.778 x 406	.50 x 1.50
#34	100025SK	0.1110 x 6	2.819 x 152	.50 x 1.50
	100026SK	0.1110 x 10	2.819 x 254	.50 x 1.50
#33	100027SK	0.1130 x 6	2.870 x 152	.50 x 1.50
	100028SK	0.1130 x 10	2.870 x 254	.50 x 1.50
#32	100029SK	0.1160 x 6	2.946 x 152	.50 x 1.50
	100030SK	0.1160 x 10	2.946 x 254	.50 x 1.50
3mm	100031SK	0.1181 x 6	3.000 x 152	.50 x 1.50
	100544SK	0.1181 x 10	3.000 x 254	.50 x 1.50
	112477SK	0.1181 x 16	3.000 x 406	.50 x 1.50
#31	100033SK	0.1200 x 6	3.048 x 152	.50 x 1.50
	100034SK	0.1200 x 10	3.048 x 254	.50 x 1.50

STOCK GUNDRILLS

Size	DMET Part#	Decimal Size (inches)	Metric Size (mm)	Driver (inches)
Kidney Coolant Hole				
1/8"	112773SK	0.1250 x 10	3.175 x 254	.75 x 2.75
	111112SK	0.1250 x 12	3.175 x 305	.75 x 2.75
	112774SK	0.1250 x 16	3.175 x 406	.75 x 2.75
	112775SK	0.1250 x 22	3.175 x 559	.75 x 2.75
	112776SK	0.1250 x 28	3.175 x 711	.75 x 2.75
	100666SK	0.1250 x 36	3.175 x 914	.75 x 2.75
#30	100545SK	0.1285 x 10	3.264 x 254	.75 x 2.75
	100546SK	0.1285 x 16	3.264 x 406	.75 x 2.75
	100547SK	0.1285 x 22	3.264 x 559	.75 x 2.75
	111776SK	0.1285 x 28	3.264 x 711	.75 x 2.75
#29	100548SK	0.1360 x 10	3.454 x 254	.75 x 2.75
	100549SK	0.1360 x 16	3.454 x 406	.75 x 2.75
	100550SK	0.1360 x 22	3.454 x 559	.75 x 2.75
9/64"	112778SK	0.1406 x 10	3.571 x 254	.75 x 2.75
	111530SK	0.1406 x 12	3.571 x 305	.75 x 2.75
	112779SK	0.1406 x 16	3.571 x 406	.75 x 2.75
	112780SK	0.1406 x 22	3.571 x 559	.75 x 2.75
#27	100047SK	0.1440 x 10	3.658 x 254	.75 x 2.75
	100048SK	0.1440 x 16	3.658 x 406	.75 x 2.75
	100049SK	0.1440 x 22	3.658 x 559	.75 x 2.75
#26	100551SK	0.1470 x 10	3.734 x 254	.75 x 2.75
	100552SK	0.1470 x 16	3.734 x 406	.75 x 2.75
	100052SK	0.1470 x 22	3.734 x 559	.75 x 2.75
#25	100553SK	0.1495 x 10	3.798 x 254	.75 x 2.75
	100554SK	0.1495 x 16	3.798 x 406	.75 x 2.75
	100555SK	0.1495 x 22	3.798 x 559	.75 x 2.75
#24	100056SK	0.1520 x 10	3.861 x 254	.75 x 2.75
	100057SK	0.1520 x 16	3.861 x 406	.75 x 2.75
	100058SK	0.1520 x 22	3.861 x 559	.75 x 2.75
5/32"	112781SK	0.1562 x 10	3.967 x 254	.75 x 2.75
	111114SK	0.1562 x 12	3.967 x 305	.75 x 2.75
	112782SK	0.1562 x 16	3.967 x 406	.75 x 2.75
	112783SK	0.1562 x 22	3.967 x 559	.75 x 2.75
	112784SK	0.1562 x 28	3.967 x 711	.75 x 2.75
	114079SK	0.1562 x 36	3.967 x 914	.75 x 2.75
4mm	112785SK	0.1575 x 10	4.000 x 254	.75 x 2.75
	112786SK	0.1575 x 16	4.000 x 406	.75 x 2.75
	112787SK	0.1575 x 22	4.000 x 559	.75 x 2.75
#21	100068SK	0.1590 x 10	4.039 x 254	.75 x 2.75
	100069SK	0.1590 x 16	4.039 x 406	.75 x 2.75
	100070SK	0.1590 x 22	4.039 x 559	.75 x 2.75
#20	100071SK	0.1610 x 10	4.089 x 254	.75 x 2.75
	100072SK	0.1610 x 16	4.089 x 406	.75 x 2.75
	100073SK	0.1610 x 22	4.089 x 559	.75 x 2.75
#19	100074SK	0.1660 x 10	4.216 x 254	.75 x 2.75
	100075SK	0.1660 x 16	4.216 x 406	.75 x 2.75
	100076SK	0.1660 x 22	4.216 x 559	.75 x 2.75

STOCK GUNDRILLS

Size	DMET Part#	Decimal Size (inches)	Metric Size (mm)	Driver (inches)
Kidney Coolant Hole				
1 1/64"	112788SK	0.1719 x 10	4.366 x 254	.75 x 2.75
	111540SK	0.1719 x 12	4.366 x 305	.75 x 2.75
	112789SK	0.1719 x 16	4.366 x 406	.75 x 2.75
	112790SK	0.1719 x 22	4.366 x 559	.75 x 2.75
#17	100556SK	0.1730 x 10	4.394 x 254	.75 x 2.75
	100557SK	0.1730 x 16	4.394 x 406	.75 x 2.75
	100085SK	0.1730 x 22	4.394 x 559	.75 x 2.75
#16	100558SK	0.1770 x 10	4.496 x 254	.75 x 2.75
	100559SK	0.1770 x 16	4.496 x 406	.75 x 2.75
	100088SK	0.1770 x 22	4.496 x 559	.75 x 2.75
#15	100089SK	0.1800 x 10	4.572 x 254	.75 x 2.75
	100090SK	0.1800 x 16	4.572 x 406	.75 x 2.75
	100091SK	0.1800 x 22	4.572 x 559	.75 x 2.75
#14	100092SK	0.1820 x 10	4.623 x 254	.75 x 2.75
	100093SK	0.1820 x 16	4.623 x 406	.75 x 2.75
	100094SK	0.1820 x 22	4.623 x 559	.75 x 2.75
#13	100095SK	0.1850 x 10	4.699 x 254	.75 x 2.75
	100096SK	0.1850 x 16	4.699 x 406	.75 x 2.75
	100097SK	0.1850 x 22	4.699 x 559	.75 x 2.75
3/16"	112791SK	0.1875 x 10	4.763 x 254	.75 x 2.75
	111116SK	0.1875 x 12	4.763 x 305	.75 x 2.75
	112792SK	0.1875 x 16	4.763 x 406	.75 x 2.75
	112793SK	0.1875 x 22	4.763 x 559	.75 x 2.75
	112794SK	0.1875 x 28	4.763 x 711	.75 x 2.75
	112795SK	0.1875 x 36	4.763 x 914	.75 x 2.75
	112796SK	0.1875 x 48	4.763 x 1219	.75 x 2.75
#12	100103SK	0.1890 x 10	4.801 x 254	.75 x 2.75
	100104SK	0.1890 x 16	4.801 x 406	.75 x 2.75
	100105SK	0.1890 x 22	4.801 x 559	.75 x 2.75
#11	100106SK	0.1910 x 10	4.851 x 254	.75 x 2.75
	100107SK	0.1910 x 16	4.851 x 406	.75 x 2.75
	100108SK	0.1910 x 22	4.851 x 559	.75 x 2.75
#10	100109SK	0.1935 x 10	4.915 x 254	.75 x 2.75
	100110SK	0.1935 x 16	4.915 x 406	.75 x 2.75
	100111SK	0.1935 x 22	4.915 x 559	.75 x 2.75
5mm	100560SK	0.1968 x 10	5.000 x 254	.75 x 2.75
	100561SK	0.1968 x 16	5.000 x 406	.75 x 2.75
	100114SK	0.1968 x 22	5.000 x 559	.75 x 2.75
#8	100115SK	0.1990 x 10	5.055 x 254	.75 x 2.75
	100116SK	0.1990 x 16	5.055 x 406	.75 x 2.75
	100117SK	0.1990 x 22	5.055 x 559	.75 x 2.75
#7	100118SK	0.2010 x 10	5.105 x 254	.75 x 2.75
	100119SK	0.2010 x 16	5.105 x 406	.75 x 2.75
	100120SK	0.2010 x 22	5.105 x 559	.75 x 2.75

STOCK GUNDRILLS

Size	DMET Part#	Decimal Size (inches)	Metric Size (mm)	Driver (inches)
Kidney Coolant Hole				
13/64"	112802SK	0.2031 x 10	5.159 x 254	.75 x 2.75
	111550SK	0.2031 x 12	5.159 x 305	.75 x 2.75
	112803SK	0.2031 x 16	5.159 x 406	.75 x 2.75
	112804SK	0.2031 x 22	5.159 x 559	.75 x 2.75
	112805SK	0.2031 x 28	5.159 x 711	.75 x 2.75
	112806SK	0.2031 x 36	5.159 x 914	.75 x 2.75
#4	100132SK	0.2090 x 10	5.309 x 254	.75 x 2.75
	100133SK	0.2090 x 16	5.309 x 406	.75 x 2.75
	100134SK	0.2090 x 22	5.309 x 559	.75 x 2.75
#3	100562SK	0.2130 x 10	5.410 x 254	.75 x 2.75
	100563SK	0.2130 x 16	5.410 x 406	.75 x 2.75
	100564SK	0.2130 x 22	5.410 x 559	.75 x 2.75
7/32"	112807SK	0.2187 x 10	5.555 x 254	.75 x 2.75
	111778SK	0.2187 x 12	5.555 x 305	.75 x 2.75
	112808SK	0.2187 x 16	5.555 x 406	.75 x 2.75
	112809SK	0.2187 x 22	5.555 x 559	.75 x 2.75
	112810SK	0.2187 x 28	5.555 x 711	.75 x 2.75
	112811SK	0.2187 x 36	5.555 x 914	.75 x 2.75
#2	100565SK	0.2210 x 10	5.613 x 254	.75 x 2.75
	100566SK	0.2210 x 16	5.613 x 406	.75 x 2.75
	100567SK	0.2210 x 22	5.613 x 559	.75 x 2.75
#1	100146SK	0.2280 x 10	5.791 x 254	.75 x 2.75
	100147SK	0.2280 x 16	5.791 x 406	.75 x 2.75
	100148SK	0.2280 x 22	5.791 x 559	.75 x 2.75
15/64"	112812SK	0.2344 x 10	5.953 x 254	.75 x 2.75
	111560SK	0.2344 x 12	5.953 x 305	.75 x 2.75
	112813SK	0.2344 x 16	5.953 x 406	.75 x 2.75
	112814SK	0.2344 x 22	5.953 x 559	.75 x 2.75
	100568SK	0.2344 x 28	5.953 x 711	.75 x 2.75
	100569SK	0.2344 x 36	5.953 x 914	.75 x 2.75
6mm	112817SK	0.2362 x 10	6.000 x 254	.75 x 2.75
	112818SK	0.2362 x 16	6.000 x 406	.75 x 2.75
	112819SK	0.2362 x 22	6.000 x 559	.75 x 2.75
Let. B	100157SK	0.2380 x 10	6.045 x 254	.75 x 2.75
	100158SK	0.2380 x 16	6.045 x 406	.75 x 2.75
	100159SK	0.2380 x 22	6.045 x 559	.75 x 2.75
Let. C	100160SK	0.2420 x 10	6.147 x 254	.75 x 2.75
	100161SK	0.2420 x 16	6.147 x 406	.75 x 2.75
	100162SK	0.2420 x 22	6.147 x 559	.75 x 2.75
Let. D	100163SK	0.2460 x 10	6.248 x 254	.75 x 2.75
	112821SK	0.2460 x 16	6.248 x 406	.75 x 2.75
	100165SK	0.2460 x 22	6.248 x 559	.75 x 2.75

Order Online!

You can now see stock pricing, up to the minute availability, enter orders and so much more!
Visit us at <https://portal.dmetool.com/> to get to started!

STOCK GUNDRILLS

Size	DMET Part#	Decimal Size (inches)	Metric Size (mm)	Driver (inches)
Kidney Coolant Hole				
1/4" & Let. E	112823SK	0.2500 x 10	6.350 x 254	.75 x 2.75
	111118SK	0.2500 x 12	6.350 x 305	.75 x 2.75
	112824SK	0.2500 x 16	6.350 x 406	.75 x 2.75
	112825SK	0.2500 x 22	6.350 x 559	.75 x 2.75
	112826SK	0.2500 x 28	6.350 x 711	.75 x 2.75
	100570SK	0.2500 x 36	6.350 x 914	.75 x 2.75
	100571SK	0.2500 x 48	6.350 x 1219	.75 x 2.75
Let. F	100572SK	0.2570 x 10	6.528 x 254	.75 x 2.75
	100573SK	0.2570 x 16	6.528 x 406	.75 x 2.75
	100574SK	0.2570 x 22	6.528 x 559	.75 x 2.75
Let. G	100175SK	0.2610 x 10	6.629 x 254	.75 x 2.75
	100176SK	0.2610 x 16	6.629 x 406	.75 x 2.75
	100177SK	0.2610 x 22	6.629 x 559	.75 x 2.75
	112478SK	0.2610 x 28	6.629 x 711	.75 x 2.75
	114080SK	0.2610 x 36	6.629 x 914	.75 x 2.75
17/64"	100575SK	0.2656 x 10	6.629 x 254	.75 x 2.75
	111570SK	0.2656 x 12	6.629 x 304	.75 x 2.75
	100576SK	0.2656 x 16	6.629 x 406	.75 x 2.75
	100577SK	0.2656 x 22	6.629 x 559	.75 x 2.75
	100181SK	0.2656 x 28	6.629 x 711	.75 x 2.75
	100578SK	0.2656 x 36	6.629 x 914	.75 x 2.75
	114081SK	0.2656 x 48	6.629 x 1219	.75 x 2.75
Let. I	100183SK	0.2720 x 10	6.909 x 254	.75 x 2.75
	100184SK	0.2720 x 16	6.909 x 406	.75 x 2.75
	100185SK	0.2720 x 22	6.909 x 559	.75 x 2.75
7mm	100186SK	0.2756 x 10	7.000 x 254	.75 x 2.75
	100187SK	0.2756 x 16	7.000 x 406	.75 x 2.75
	100188SK	0.2756 x 22	7.000 x 559	.75 x 2.75
Let. J	100189SK	0.2770 x 10	7.036 x 254	.75 x 2.75
	100190SK	0.2770 x 16	7.036 x 406	.75 x 2.75
	100191SK	0.2770 x 22	7.036 x 559	.75 x 2.75
9/32"	100192SK	0.2812 x 10	7.142 x 254	.75 x 2.75
	111580SK	0.2812 x 12	7.142 x 304	.75 x 2.75
	100579SK	0.2812 x 16	7.142 x 406	.75 x 2.75
	100580SK	0.2812 x 22	7.142 x 559	.75 x 2.75
	100195SK	0.2812 x 28	7.142 x 711	.75 x 2.75
	100581SK	0.2812 x 36	7.142 x 914	.75 x 2.75
	100582SK	0.2812 x 48	7.142 x 1219	.75 x 2.75
Let. L	100198SK	0.2900 x 10	7.366 x 254	.75 x 2.75
	100199SK	0.2900 x 16	7.366 x 406	.75 x 2.75
	100583SK	0.2900 x 22	7.366 x 559	.75 x 2.75
19/64"	112846SK	0.2969 x 10	7.541 x 254	.75 x 2.75
	111590SK	0.2969 x 12	7.541 x 304	.75 x 2.75
	112847SK	0.2969 x 16	7.541 x 406	.75 x 2.75
	112848SK	0.2969 x 22	7.541 x 559	.75 x 2.75
	112849SK	0.2969 x 28	7.541 x 711	.75 x 2.75
	112850SK	0.2969 x 36	7.541 x 914	.75 x 2.75

STOCK GUNDRILLS

Size	DMET Part#	Decimal Size (inches)	Metric Size (mm)	Driver (inches)
Kidney Coolant Hole				
Let. N	100209SK	0.3020 x 10	7.671 x 254	.75 x 2.75
	100210SK	0.3020 x 16	7.671 x 406	.75 x 2.75
	100211SK	0.3020 x 22	7.671 x 559	.75 x 2.75
	112851SK	0.3125 x 10	7.938 x 254	.75 x 2.75
5/16"	111121SK	0.3125 x 12	7.938 x 304	.75 x 2.75
	112852SK	0.3125 x 16	7.938 x 406	.75 x 2.75
	112853SK	0.3125 x 22	7.938 x 559	.75 x 2.75
	112854SK	0.3125 x 28	7.938 x 711	.75 x 2.75
	112855SK	0.3125 x 36	7.938 x 914	.75 x 2.75
	112856SK	0.3125 x 48	7.938 x 1219	.75 x 2.75
8mm	100218SK	0.3150 x 10	8.000 x 254	.75 x 2.75
	100219SK	0.3150 x 16	8.000 x 406	.75 x 2.75
	100220SK	0.3150 x 22	8.000 x 559	.75 x 2.75
	114082SK	0.3150 x 36	8.000 x 914	.75 x 2.75
Let. O	100221SK	0.3160 x 10	8.026 x 254	.75 x 2.75
	100222SK	0.3160 x 16	8.026 x 406	.75 x 2.75
	100223SK	0.3160 x 22	8.026 x 559	.75 x 2.75

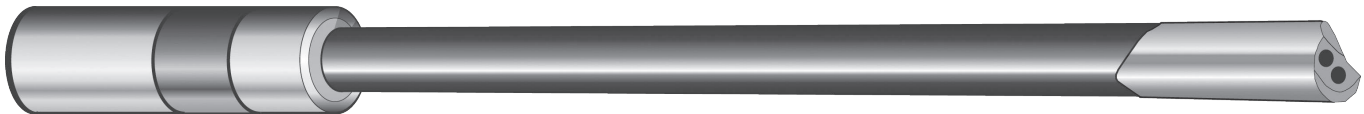

STOCK GUNDRILLS

Size	DMET Part#	Decimal Size (inches)	Metric Size (mm)	Driver (inches)
Two Coolant Hole				
Let. P	100225	0.3230 x 10	8.204 x 254	.75 x 2.75
	100226	0.3230 x 16	8.204 x 406	.75 x 2.75
	100646	0.3230 x 22	8.204 x 559	.75 x 2.75
21/64"	100227	0.3281 x 10	8.204 x 254	.75 x 2.75
	111610	0.3281 x 12	8.204 x 305	.75 x 2.75
	100228	0.3281 x 16	8.204 x 406	.75 x 2.75
	100229	0.3281 x 22	8.204 x 559	.75 x 2.75
	100230	0.3281 x 28	8.204 x 711	.75 x 2.75
	100231	0.3281 x 36	8.204 x 914	.75 x 2.75
Let. Q	100232	0.3320 x 10	8.433 x 254	.75 x 2.75
	100233	0.3320 x 16	8.433 x 406	.75 x 2.75
	100234	0.3320 x 22	8.433 x 559	.75 x 2.75
Let. R	100235	0.3390 x 10	8.611 x 254	.75 x 2.75
	100236	0.3390 x 16	8.611 x 406	.75 x 2.75
	100237	0.3390 x 22	8.611 x 559	.75 x 2.75

Order Online!

You can now see stock pricing, up to the minute availability, enter orders and so much more!
Visit us at <https://portal.dmetool.com/> to get to started!

STOCK GUNDRILLS

Size	DMET Part#	Decimal Size (inches)	Metric Size (mm)	Driver (inches)
Two Coolant Hole				
11/32"	100238	0.3437 x 10	8.730 x 254	.75 x 2.75
	111620	0.3437 x 12	8.730 x 305	.75 x 2.75
	100239	0.3437 x 16	8.730 x 406	.75 x 2.75
	100240	0.3437 x 22	8.730 x 559	.75 x 2.75
	100241	0.3437 x 28	8.730 x 711	.75 x 2.75
	100242	0.3437 x 36	8.730 x 914	.75 x 2.75
	100243	0.3437 x 48	8.730 x 1219	.75 x 2.75
Let. S	100244	0.3480 x 10	8.839 x 254	.75 x 2.75
	100245	0.3480 x 16	8.839 x 406	.75 x 2.75
	100246	0.3480 x 22	8.839 x 559	.75 x 2.75
9mm	100438	0.3543 x 10	9.000 x 254	.75 x 2.75
	100439	0.3543 x 16	9.000 x 406	.75 x 2.75
	100440	0.3543 x 22	9.000 x 559	.75 x 2.75
23/64"	100253	0.3594 x 10	9.129 x 254	.75 x 2.75
	111630	0.3594 x 12	9.129 x 305	.75 x 2.75
	100254	0.3594 x 16	9.129 x 406	.75 x 2.75
	100255	0.3594 x 22	9.129 x 559	.75 x 2.75
	100256	0.3594 x 28	9.129 x 711	.75 x 2.75
	100257	0.3594 x 36	9.129 x 914	.75 x 2.75
Let. U	100258	0.3680 x 10	9.347 x 254	.75 x 2.75
	100259	0.3680 x 16	9.347 x 406	.75 x 2.75
	100260	0.3680 x 22	9.347 x 559	.75 x 2.75
3/8"	100261	0.3750 x 10	9.525 x 254	.75 x 2.75
	111122	0.3750 x 12	9.525 x 305	.75 x 2.75
	100262	0.3750 x 16	9.525 x 406	.75 x 2.75
	100263	0.3750 x 22	9.525 x 559	.75 x 2.75
	100264	0.3750 x 28	9.525 x 711	.75 x 2.75
	100265	0.3750 x 36	9.525 x 914	.75 x 2.75
	100266	0.3750 x 48	9.525 x 1219	.75 x 2.75
Let. V	100668	0.3770 x 10	9.576 x 254	.75 x 2.75
	100267	0.3770 x 16	9.576 x 406	.75 x 2.75
	100268	0.3770 x 22	9.576 x 559	.75 x 2.75
	100269	0.3770 x 36	9.576 x 914	.75 x 2.75
Let. W	100270	0.3860 x 16	9.804 x 406	.75 x 2.75
	100271	0.3860 x 22	9.804 x 559	.75 x 2.75
	100272	0.3860 x 36	9.804 x 914	.75 x 2.75
25/64"	100647	0.3906 x 10	9.921 x 254	.75 x 2.75
	111640	0.3906 x 12	9.921 x 305	.75 x 2.75
	100274	0.3906 x 16	9.921 x 406	.75 x 2.75
	100275	0.3906 x 22	9.921 x 559	.75 x 2.75
	100276	0.3906 x 28	9.921 x 711	.75 x 2.75
	100277	0.3906 x 36	9.921 x 914	.75 x 2.75

Order Online!

You can now see stock pricing, up to the minute availability, enter orders and so much more!
Visit us at <https://portal.dmetool.com/> to get to started!

STOCK GUNDRILLS

Size	DMET Part#	Decimal Size (inches)	Metric Size (mm)	Driver (inches)
Two Coolant Hole				
10mm	114083	0.3937 x 10	10.000 x 254	.75 x 2.75
	100278	0.3937 x 16	10.000 x 406	.75 x 2.75
	100279	0.3937 x 22	10.000 x 559	.75 x 2.75
	100280	0.3937 x 36	10.000 x 914	.75 x 2.75
	114084	0.3937 x 48	10.000 x 1219	.75 x 2.75
Let. X	100281	0.3970 x 16	10.084 x 406	.75 x 2.75
	100282	0.3970 x 22	10.084 x 559	.75 x 2.75
	100283	0.3970 x 36	10.084 x 914	.75 x 2.75
13/32"	100287	0.4062 x 10	10.317 x 254	.75 x 2.75
	111650	0.4062 x 12	10.317 x 305	.75 x 2.75
	100288	0.4062 x 16	10.317 x 406	.75 x 2.75
	100289	0.4062 x 22	10.317 x 559	.75 x 2.75
	100290	0.4062 x 28	10.317 x 711	.75 x 2.75
	100291	0.4062 x 36	10.317 x 914	.75 x 2.75
	100292	0.4062 x 48	10.317 x 1219	.75 x 2.75
27/64"	100296	0.4219 x 10	10.716 x 254	.75 x 2.75
	111660	0.4219 x 12	10.716 x 305	.75 x 2.75
	100297	0.4219 x 16	10.716 x 406	.75 x 2.75
	100298	0.4219 x 22	10.716 x 559	.75 x 2.75
	100299	0.4219 x 28	10.716 x 711	.75 x 2.75
	100300	0.4219 x 36	10.716 x 914	.75 x 2.75
	112479	0.4219 x 48	10.716 x 1219	.75 x 2.75
11mm	100301	0.4331 x 16	11.000 x 406	.75 x 2.75
	100302	0.4331 x 22	11.000 x 559	.75 x 2.75
	100303	0.4331 x 36	11.000 x 914	.75 x 2.75
7/16"	100304	0.4375 x 10	11.113 x 254	.75 x 2.75
	111123	0.4375 x 12	11.113 x 305	.75 x 2.75
	100305	0.4375 x 16	11.113 x 406	.75 x 2.75
	100306	0.4375 x 22	11.113 x 559	.75 x 2.75
	100307	0.4375 x 28	11.113 x 711	.75 x 2.75
	100308	0.4375 x 36	11.113 x 914	.75 x 2.75
	100309	0.4375 x 48	11.113 x 1219	.75 x 2.75
29/64"	100310	0.4531 x 10	11.509 x 254	.75 x 2.75
	111670	0.4531 x 12	11.509 x 305	.75 x 2.75
	100311	0.4531 x 16	11.509 x 406	.75 x 2.75
	100312	0.4531 x 22	11.509 x 559	.75 x 2.75
	100313	0.4531 x 28	11.509 x 711	.75 x 2.75
	100314	0.4531 x 36	11.509 x 914	.75 x 2.75
	112480	0.4531 x 48	11.509 x 1219	.75 x 2.75
15/32"	100315	0.4687 x 10	11.905 x 254	.75 x 2.75
	111680	0.4687 x 12	11.905 x 305	.75 x 2.75
	100316	0.4687 x 16	11.905 x 406	.75 x 2.75
	100317	0.4687 x 22	11.905 x 559	.75 x 2.75
	100318	0.4687 x 28	11.905 x 711	.75 x 2.75
	100319	0.4687 x 36	11.905 x 914	.75 x 2.75
	100320	0.4687 x 48	11.905 x 1219	.75 x 2.75

STOCK GUNDRILLS

Size	DMET Part#	Decimal Size (inches)	Metric Size (mm)	Driver (inches)
Two Coolant Hole				
12mm	100321	0.4724 x 16	12.000 x 406	.75 x 2.75
	100322	0.4724 x 22	12.000 x 559	.75 x 2.75
	100323	0.4724 x 36	12.000 x 914	.75 x 2.75
31/64"	114085	0.4844 x 10	12.304 x 254	.75 x 2.75
	111690	0.4844 x 12	12.304 x 305	.75 x 2.75
	100325	0.4844 x 16	12.304 x 406	.75 x 2.75
	100326	0.4844 x 22	12.304 x 559	.75 x 2.75
	100327	0.4844 x 28	12.304 x 711	.75 x 2.75
	100328	0.4844 x 36	12.304 x 914	.75 x 2.75
1/2"	100329	0.5000 x 10	12.700 x 254	.75 x 2.75
	111720	0.5000 x 12	12.700 x 305	.75 x 2.75
	100330	0.5000 x 16	12.700 x 406	.75 x 2.75
	100331	0.5000 x 22	12.700 x 559	.75 x 2.75
	100332	0.5000 x 28	12.700 x 711	.75 x 2.75
	100333	0.5000 x 36	12.700 x 914	.75 x 2.75
	100334	0.5000 x 48	12.700 x 1219	.75 x 2.75
33/64"	100335	0.5156 x 16	13.096 x 406	1.00 x 2.75
	100336	0.5156 x 22	13.096 x 559	1.00 x 2.75
	100337	0.5156 x 36	13.096 x 914	1.00 x 2.75
17/32"	100338	0.5312 x 16	13.492 x 406	1.00 x 2.75
	100339	0.5312 x 22	13.492 x 559	1.00 x 2.75
	100340	0.5312 x 36	13.492 x 914	1.00 x 2.75
	114086	0.5312 x 48	13.492 x 1219	1.00 x 2.75
35/64"	100341	0.5469 x 16	13.891 x 406	1.00 x 2.75
	100342	0.5469 x 22	13.891 x 559	1.00 x 2.75
	100343	0.5469 x 36	13.891 x 914	1.00 x 2.75
9/16"	100344	0.5625 x 16	14.288 x 406	1.00 x 2.75
	100345	0.5625 x 22	14.288 x 559	1.00 x 2.75
	119839	0.5625 x 28	14.288 x 711	1.00 x 2.75
	100346	0.5625 x 36	14.288 x 914	1.00 x 2.75
	100347	0.5625 x 48	14.288 x 1219	1.00 x 2.75
37/64"	100348	0.5781 x 16	14.684 x 406	1.00 x 2.75
	100349	0.5781 x 22	14.684 x 559	1.00 x 2.75
	100350	0.5781 x 36	14.684 x 914	1.00 x 2.75
19/32"	100351	0.5937 x 16	15.080 x 406	1.00 x 2.75
	100352	0.5937 x 22	15.080 x 559	1.00 x 2.75
	100353	0.5937 x 36	15.080 x 914	1.00 x 2.75
	112481	0.5937 x 48	15.080 x 1219	1.00 x 2.75
39/64"	100354	0.6094 x 16	15.479 x 406	1.00 x 2.75
	100355	0.6094 x 22	15.479 x 559	1.00 x 2.75
	100356	0.6094 x 36	15.479 x 914	1.00 x 2.75
5/8"	100357	0.6250 x 16	15.875 x 406	1.00 x 2.75
	100358	0.6250 x 22	15.875 x 559	1.00 x 2.75
	114087	0.6250 x 28	15.875 x 711	1.00 x 2.75
	100359	0.6250 x 36	15.875 x 914	1.00 x 2.75
	100360	0.6250 x 48	15.875 x 1219	1.00 x 2.75

STOCK GUNDRILLS

Size	DMET Part#	Decimal Size (inches)	Metric Size (mm)	Driver (inches)
Two Coolant Hole				
41/64"	100361	0.6406 x 16	16.271 x 406	1.00 x 2.75
	100362	0.6406 x 22	16.271 x 559	1.00 x 2.75
	100363	0.6406 x 36	16.271 x 914	1.00 x 2.75
21/32"	100364	0.6562 x 16	16.667 x 406	1.00 x 2.75
	100365	0.6562 x 22	16.667 x 559	1.00 x 2.75
	100366	0.6562 x 36	16.667 x 914	1.00 x 2.75
43/64"	100367	0.6719 x 16	17.066 x 406	1.00 x 2.75
	100368	0.6719 x 22	17.066 x 559	1.00 x 2.75
	100369	0.6719 x 36	17.066 x 914	1.00x 2.75
11/16"	100370	0.6875 x 16	17.463 x 406	1.00 x 2.75
	100371	0.6875 x 22	17.463 x 559	1.00 x 2.75
	119840	0.6875 x 28	17.463 x 711	1.00 x 2.75
	100372	0.6875 x 36	17.463 x 914	1.00 x 2.75
	100373	0.6875 x 48	17.463 x 1219	1.00 x 2.75
45/64"	100656	0.7031 x 16	17.859 x 406	1.00 x 2.75
	114088	0.7031 x 22	17.859 x 559	1.00 x 2.75
	100376	0.7031 x 36	17.859 x 914	1.00 x 2.75
	114089	0.7031 x 48	17.859 x 1219	1.00 x 2.75
23/32"	100377	0.7187 x 16	18.255 x 406	1.00 x 2.75
	100378	0.7187 x 22	18.255 x 559	1.00 x 2.75
	100379	0.7187 x 36	18.255 x 914	1.00 x 2.75
	100669	0.7187 x 48	18.255 x 1219	1.00 x 2.75
47/64"	100380	0.7344 x 16	18.654 x 406	1.00 x 2.75
	100381	0.7344 x 22	18.654 x 559	1.00 x 2.75
	100382	0.7344 x 36	18.654 x 914	1.00 x 2.75
3/4"	100383	0.7500 x 16	19.050 x 406	1.00 x 2.75
	100384	0.7500 x 22	19.050 x 559	1.00 x 2.75
	112482	0.7500 x 28	19.050 x 711	1.00 x 2.75
	100385	0.7500 x 36	19.050 x 914	1.00 x 2.75
	100386	0.7500 x 48	19.050 x 1219	1.00 x 2.75
49/64"	100441	0.7656 x 22	19.446 x 559	1.25 x 2.75
	100442	0.7656 x 36	19.446 x 914	1.25 x 2.75
	100443	0.7656 x 48	19.446 x 1219	1.25 x 2.75
25/32"	100389	0.7812 x 22	19.842 x 559	1.25 x 2.75
	100390	0.7812 x 36	19.842 x 914	1.25 x 2.75
	100648	0.7812 x 48	19.842 x 1219	1.25 x 2.75
51/64"	100391	0.7969 x 22	20.242 x 559	1.25 x 2.75
	100392	0.7969 x 36	20.242 x 914	1.25 x 2.75
	100649	0.7969 x 48	20.242 x 1219	1.25 x 2.75
13/16"	100393	0.8125 x 22	20.638 x 559	1.25 x 2.75
	100394	0.8125 x 36	20.638 x 914	1.25 x 2.75
	100395	0.8125 x 48	20.638 x 1219	1.25 x 2.75
53/64"	100444	0.8281 x 22	21.034 x 559	1.25 x 2.75
	100445	0.8281 x 36	21.034 x 914	1.25 x 2.75
	100446	0.8281 x 48	21.034 x 1219	1.25 x 2.75

Order Online!

You can now see stock pricing, up to the minute availability, enter orders and so much more!
Visit us at <https://portal.dmetool.com/> to get to started!

STOCK GUNDRILLS

Size	DMET Part#	Decimal Size (inches)	Metric Size (mm)	Driver (inches)
Two Coolant Hole				
27/32"	100398	0.8437 x 22	21.430 x 559	1.25 x 2.75
	100399	0.8437 x 36	21.430 x 914	1.25 x 2.75
	100650	0.8437 x 48	21.430 x 1219	1.25 x 2.75
55/64"	100400	0.8594 x 22	21.829 x 559	1.25 x 2.75
	100401	0.8594 x 36	21.829 x 914	1.25 x 2.75
	100651	0.8594 x 48	21.829 x 1219	1.25 x 2.75
7/8"	100402	0.8750 x 22	22.225 x 559	1.25 x 2.75
	100403	0.8750 x 36	22.225 x 914	1.25 x 2.75
	100404	0.8750 x 48	22.225 x 1219	1.25 x 2.75
57/64"	100447	0.8906 x 22	22.621 x 559	1.25 x 2.75
	100448	0.8906 x 36	22.621 x 914	1.25 x 2.75
	100449	0.8906 x 48	22.621 x 1219	1.25 x 2.75
29/32"	100407	0.9062 x 22	23.017 x 559	1.25 x 2.75
	100408	0.9062 x 36	23.017 x 914	1.25 x 2.75
	100652	0.9062 x 48	23.017 x 1219	1.25 x 2.75
59/64"	100409	0.9219 x 22	23.416 x 559	1.25 x 2.75
	100410	0.9219 x 36	23.416 x 914	1.25 x 2.75
	100653	0.9219 x 48	23.416 x 1219	1.25 x 2.75
15/16"	114090	0.9375 x 16	23.813 x 406	1.25 x 2.75
	100411	0.9375 x 22	23.813 x 559	1.25 x 2.75
	100412	0.9375 x 36	23.813 x 914	1.25 x 2.75
	100654	0.9375 x 48	23.813 x 1219	1.25 x 2.75
61/64"	100450	0.9531 x 22	24.209 x 559	1.25 x 2.75
	100451	0.9531 x 36	24.209 x 914	1.25 x 2.75
	100452	0.9531 x 48	24.209 x 1219	1.25 x 2.75
31/32"	100655	0.9687 x 22	24.605 x 559	1.25 x 2.75
	100417	0.9687 x 36	24.605 x 914	1.25 x 2.75
	100670	0.9687 x 48	24.605 x 1219	1.25 x 2.75
63/64"	100418	0.9844 x 22	25.003 x 559	1.25 x 2.75
	100419	0.9844 x 36	25.003 x 914	1.25 x 2.75
	100657	0.9844 x 48	25.003 x 1219	1.25 x 2.75
1"	100690	1.0000 x 16	25.400 x 406	1.25 x 2.75
	100420	1.0000 x 22	25.400 x 559	1.25 x 2.75
	100689	1.0000 x 28	25.400 x 711	1.25 x 2.75
	100421	1.0000 x 36	25.400 x 914	1.25 x 2.75
	100422	1.0000 x 48	25.400 x 1219	1.25 x 2.75
11/16"	100453	1.0625 x 22	26.987 x 559	1.5 x 2.75
	100454	1.0625 x 36	26.987 x 914	1.5 x 2.75
	100455	1.0625 x 48	26.987 x 1219	1.5 x 2.75
1 1/8"	100658	1.1250 x 22	28.575 x 559	1.5 x 2.75
	100425	1.1250 x 36	28.575 x 914	1.5 x 2.75
	100426	1.1250 x 48	28.575 x 1219	1.5 x 2.75
1 3/16"	100659	1.1875 x 22	30.162 x 559	1.5 x 2.75
	100660	1.1875 x 36	30.162 x 914	1.5 x 2.75
	100428	1.1875 x 48	30.162 x 1219	1.5 x 2.75

STOCK GUNDRILLS				
Size	DMET Part#	Decimal Size (inches)	Metric Size (mm)	Driver (inches)
Two Coolant Hole				
1 1/4"	100661	1.2500 x 22	31.750 x 559	1.5 x 2.75
	100429	1.2500 x 36	31.750 x 914	1.5 x 2.75
	100430	1.2500 x 48	31.750 x 1219	1.5 x 2.75
1 5/16"	100662	1.3125 x 22	33.337 x 559	1.5 x 2.75
	100431	1.3125 x 36	33.337 x 914	1.5 x 2.75
	100432	1.3125 x 48	33.337 x 1219	1.5 x 2.75
1 3/8"	100663	1.3750 x 22	34.925 x 559	1.5 x 2.75
	100433	1.3750 x 36	34.925 x 914	1.5 x 2.75
	100434	1.3750 x 48	34.925 x 1219	1.5 x 2.75
7/16"	100664	1.4375 x 36	36.512 x 914	1.5 x 2.75
	100436	1.4375 x 48	36.512 x 1219	1.5 x 2.75
1 1/2"	100437	1.5000 x 36	38.100 x 914	1.5 x 2.75
	100667	1.5000 x 48	38.100 x 1219	1.5 x 2.75

Order Online!

You can now see stock pricing, up to the minute availability, enter orders and so much more!
 Visit us at <https://portal.dmetool.com/> to get to started!

YOUR COMPLETE SOURCE FOR SINGLE FLUTE GUNDRILLS

DRILL MASTERS
Eldorado Tool

RUSH SERVICE
1-800-658-8855

SPECIAL DESIGN

Gundrills are available in range size 0.125 to 1.000, any std length (to 48"), std. sharpening, and contour, in 5 working days with std. components. When you need single flute gundrills fast, you only have to call Drill Masters-Eldorado Tool for quick and fast results.

NOW

WHEN YOU NEED THEM

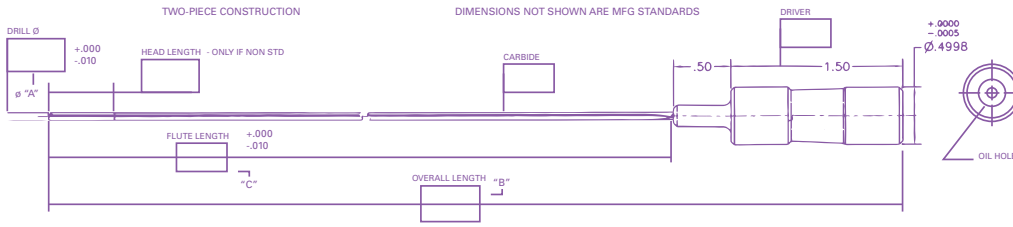

STOCK SOLID CARBIDE GUNDRILLS

Size	DMET Part#	Decimal Size (inches)	Metric Size (mm)	Driver (inches)
0.0394" Dia. To 0.1181" Dia.				
1.0mm	101010SC	0.0394 x 5	1.000 x 127	.50 x 2
1.2mm	101030SC	0.0472 x 5	1.200 x 127	.50 x 2
1.4mm	100682SC	0.0550 x 6	1.400 x 152	.50 x 2
	101051SC	0.0550 x 8	1.400 x 203	.50 x 2
1.5mm	101080SC	0.0591 x 6	1.500 x 152	.50 x 2
	101081SC	0.0591 x 8	1.500 x 203	.50 x 2
1/16"	100683SC	0.0625 x 6	1.587 x 152	.50 x 2
	101101SC	0.0625 x 8	1.587 x 203	.50 x 2
	100687SC	0.0625 x 10	1.587 x 254	.50 x 2
1.8mm	100684SC	0.0700 x 6	1.778 x 152	.50 x 2
	101131SC	0.0700 x 8	1.778 x 203	.50 x 2
	101132SC	0.0700 x 10	1.778 x 254	.50 x 2
5/64"	100685SC	0.0781 x 6	1.983 x 152	.50 x 2
	101151SC	0.0781 x 8	1.983 x 203	.50 x 2
	100688SC	0.0781 x 10	1.983 x 254	.50 x 2
2mm	101170SC	0.0787 x 6	2.000 x 152	.50 x 2
	101171SC	0.0787 x 8	2.000 x 203	.50 x 2
	101172SC	0.0787 x 10	2.000 x 254	.50 x 2
#43	101200SC	0.0890 x 6	2.260 x 152	.50 x 2
	101201SC	0.0890 x 8	2.260 x 203	.50 x 2
	101202SC	0.0890 x 10	2.260 x 254	.50 x 2
3/32"	100686SC	0.0937 x 6	2.379 x 152	.50 x 2
	101221SC	0.0937 x 8	2.379 x 203	.50 x 2
	100692SC	0.0937 x 10	2.379 x 254	.50 x 2
2.5mm	101250SC	0.0984 x 6	2.500 x 152	.50 x 2
	101251SC	0.0984 x 8	2.500 x 203	.50 x 2
	101252SC	0.0984 x 10	2.500 x 254	.50 x 2
#39	101255SC	0.0995 x 6	2.527 x 152	.50 x 2
	101256SC	0.0995 x 8	2.527 x 203	.50 x 2
	101257SC	0.0995 x 10	2.527 x 254	.50 x 2
#38	101260SC	0.1015 x 6	2.578 x 152	.50 x 2
	101261SC	0.1015 x 8	2.578 x 203	.50 x 2
	101262SC	0.1015 x 10	2.578 x 254	.50 x 2
#36	101265SC	0.1065 x 6	2.705 x 152	.50 x 2
	101266SC	0.1065 x 8	2.705 x 203	.50 x 2
	101267SC	0.1065 x 10	2.705 x 254	.50 x 2
7/64"	100693SC	0.1094 x 6	2.778 x 152	.50 x 2
	101271SC	0.1094 x 8	2.778 x 203	.50 x 2
	100694SC	0.1094 x 10	2.778 x 254	.50 x 2
3mm	101300SC	0.1181 x 6	3.000 x 152	.50 x 2
	101301SC	0.1181 x 8	3.200 x 203	.50 x 2
	101302SC	0.1181 x 10	3.400 x 254	.50 x 2

STOCK SOLID CARBIDE GUNDRILLS

Size	DMET Part#	Decimal Size (inches)	Metric Size (mm)	Driver (inches)
0.1250" Dia. To 0.3125" Dia.				
1/8"	100696SC	0.1250 x 6	3.175 x 152	.50 x 2
	101341SC	0.1250 x 8	3.175 x 203	.50 x 2
	100697SC	0.1250 x 10	3.175 x 254	.50 x 2
	101343SC	0.1250 x 12	3.175 x 304	.50 x 2
3.5mm	101381SC	0.1378 x 8	3.500 x 203	.50 x 2
	101382SC	0.1378 x 10	3.500 x 254	.50 x 2
9/64"	101411SC	0.1406 x 8	3.571 x 203	.50 x 2
	101412SC	0.1406 x 10	3.571 x 254	.50 x 2
	101413SC	0.1406 x 12	3.571 x 304	.50 x 2
5/32"	101441SC	0.1562 x 8	3.967 x 203	.50 x 2
	101442SC	0.1562 x 10	3.967 x 254	.50 x 2
	101443SC	0.1562 x 12	3.967 x 304	.50 x 2
4mm	101471SC	0.1575 x 8	4.000 x 203	.50 x 2
	101472SC	0.1575 x 10	4.000 x 254	.50 x 2
	101473SC	0.1575 x 12	4.000 x 304	.50 x 2
11/64"	101501SC	0.1719 x 8	4.366 x 203	.50 x 2
	101502SC	0.1719 x 10	4.366 x 254	.50 x 2
	101503SC	0.1719 x 12	4.366 x 304	.50 x 2
3/16"	101532SC	0.1875 x 10	4.762 x 254	.50 x 2
	101533SC	0.1875 x 12	4.762 x 304	.50 x 2
5mm	101572SC	0.1968 x 10	5.000 x 254	.50 x 2
	101573SC	0.1968 x 12	5.000 x 304	.50 x 2
13/64"	101602SC	0.2031 x 10	5.158 x 254	.50 x 2
	101603SC	0.2031 x 12	5.158 x 304	.50 x 2
7/32"	101632SC	0.2187 x 10	5.554 x 254	.50 x 2
	101633SC	0.2187 x 12	5.554 x 304	.50 x 2
15/64"	101662SC	0.2344 x 10	5.953 x 254	.50 x 2
	101663SC	0.2344 x 12	5.953 x 304	.50 x 2
6mm	101692SC	0.2362 x 10	6.000 x 254	.50 x 2
	101693SC	0.2362 x 12	6.000 x 304	.50 x 2
1/4"	101722SC	0.2500 x 10	6.350 x 254	.50 x 2
	101723SC	0.2500 x 12	6.350 x 304	.50 x 2
17/64"	101742SC	0.2656 x 10	6.746 x 254	.50 x 2
	101743SC	0.2656 x 12	6.746 x 304	.50 x 2
9/32"	101772SC	0.2812 x 10	7.142 x 254	.50 x 2
	101773SC	0.2812 x 12	7.142 x 304	.50 x 2
19/64"	101802SC	0.2969 x 10	7.541 x 254	.50 x 2
	101803SC	0.2969 x 12	7.541 x 304	.50 x 2
5/16"	101852SC	0.3125 x 10	7.937 x 254	.50 x 2
	101853SC	0.3125 x 12	7.937 x 304	.50 x 2

Order Online!

You can now see stock pricing, up to the minute availability, enter orders and so much more!
Visit us at <https://portal.dmetool.com/> to get to started!



TIALN FUTURA COATING



STOCK SOLID CARBIDE TIALN FUTURA COATED GUNDRILLS

Size	DMET Part#	Decimal Size (inches)	Metric Size (mm)	Driver (inches)
0.0394" Dia. To 0.1562" Dia.				
1.0mm	201010SC	0.0394 x 5	1.000 x 127	.50 x 2
1.2mm	201030SC	0.0472 x 5	1.200 x 127	.50 x 2
1.4mm	200682SC	0.0550 x 6	1.397 x 152	.50 x 2
	201051SC	0.0550 x 8	1.400 x 203	.50 x 2
1.5mm	201080SC	0.0591 x 6	1.500 x 152	.50 x 2
	201081SC	0.0591 x 8	1.500 x 203	.50 x 2
1/16"	200683SC	0.0625 x 6	1.587 x 152	.50 x 2
	201101SC	0.0625 x 8	1.587 x 203	.50 x 2
	200687SC	0.0625 x 10	1.587 x 254	.50 x 2
1.8mm	200684SC	0.0700 x 6	1.778 x 152	.50 x 2
	201131SC	0.0700 x 8	1.778 x 203	.50 x 2
	201132SC	0.0700 x 10	1.778 x 254	.50 x 2
5/64"	200685SC	0.0781 x 6	1.983 x 152	.50 x 2
	201151SC	0.0781 x 8	1.983 x 203	.50 x 2
	200688SC	0.0781 x 10	1.983 x 254	.50 x 2
2mm	201170SC	0.0787 x 6	2.000 x 152	.50 x 2
	201171SC	0.0787 x 8	2.000 x 203	.50 x 2
	201172SC	0.0787 x 10	2.000 x 254	.50 x 2
#43	201200SC	0.0890 x 6	2.260 x 152	.50 x 2
	201201SC	0.0890 x 8	2.260 x 203	.50 x 2
	201202SC	0.0890 x 10	2.260 x 254	.50 x 2
3/32"	200686SC	0.0937 x 6	2.379 x 152	.50 x 2
	201221SC	0.0937 x 8	2.379 x 203	.50 x 2
	200692SC	0.0937 x 10	2.379 x 254	.50 x 2
2.5mm	201250SC	0.0984 x 6	2.500 x 152	.50 x 2
	201251SC	0.0984 x 8	2.500 x 203	.50 x 2
	201252SC	0.0984 x 10	2.500 x 254	.50 x 2
#39	201255SC	0.0995 x 6	2.527 x 152	.50 x 2
	201256SC	0.0995 x 8	2.527 x 203	.50 x 2
	201257SC	0.0995 x 10	2.527 x 254	.50 x 2
#38	201260SC	0.1015 x 6	2.578 x 152	.50 x 2
	201261SC	0.1015 x 8	2.578 x 203	.50 x 2
	201262SC	0.1015 x 10	2.578 x 254	.50 x 2
#36	201265SC	0.1065 x 6	2.705 x 152	.50 x 2
	201266SC	0.1065 x 8	2.705 x 203	.50 x 2
	201267SC	0.1065 x 10	2.705 x 254	.50 x 2
7/64"	200693SC	0.1094 x 6	2.778 x 152	.50 x 2
	201271SC	0.1094 x 8	2.778 x 203	.50 x 2
	200694SC	0.1094 x 10	2.778 x 254	.50 x 2
3mm	201300SC	0.1181 x 6	3.000 x 152	.50 x 2
	201301SC	0.1181 x 8	3.200 x 203	.50 x 2
	201302SC	0.1181 x 10	3.400 x 254	.50 x 2

NEW

STOCK SOLID CARBIDE TIALN FUTURA COATED GUNDRILLS

Size	DMET Part#	Decimal Size (inches)	Metric Size (mm)	Driver (inches)
0.1250" Dia. To 0.3125" Dia.				
1/8"	200696SC	0.1250 x 6	3.175 x 152	.50 x 2
	201341SC	0.1250 x 8	3.175 x 203	.50 x 2
	200697SC	0.1250 x 10	3.175 x 254	.50 x 2
	201343SC	0.1250 x 12	3.175 x 304	.50 x 2
3.5mm	201381SC	0.1378 x 8	3.500 x 203	.50 x 2
	201382SC	0.1378 x 10	3.500 x 254	.50 x 2
9/64"	201411SC	0.1406 x 8	3.571 x 203	.50 x 2
	201412SC	0.1406 x 10	3.571 x 254	.50 x 2
	201413SC	0.1406 x 12	3.571 x 304	.50 x 2
5/32"	201441SC	0.1562 x 8	3.967 x 203	.50 x 2
	201442SC	0.1562 x 10	3.967 x 254	.50 x 2
	201443SC	0.1562 x 12	3.967 x 304	.50 x 2
4mm	201471SC	0.1575 x 8	4.000 x 203	.50 x 2
	201472SC	0.1575 x 10	4.000 x 254	.50 x 2
	201473SC	0.1575 x 12	4.000 x 304	.50 x 2
11/64"	201501SC	0.1719 x 8	4.366 x 203	.50 x 2
	201502SC	0.1719 x 10	4.366 x 254	.50 x 2
	201503SC	0.1719 x 12	4.366 x 304	.50 x 2
3/16"	201532SC	0.1875 x 10	4.762 x 254	.50 x 2
	201533SC	0.1875 x 12	4.762 x 304	.50 x 2
5mm	201572SC	0.1968 x 10	5.000 x 254	.50 x 2
	201573SC	0.1968 x 12	5.000 x 304	.50 x 2
13/64"	201602SC	0.2031 x 10	5.158 x 254	.50 x 2
	201603SC	0.2031 x 12	5.158 x 304	.50 x 2
7/32"	201632SC	0.2187 x 10	5.554 x 254	.50 x 2
	201633SC	0.2187 x 12	5.554 x 304	.50 x 2
15/64"	201662SC	0.2344 x 10	5.953 x 254	.50 x 2
	201663SC	0.2344 x 12	5.953 x 304	.50 x 2
6mm	201692SC	0.2362 x 10	6.000 x 254	.50 x 2
	201693SC	0.2362 x 12	6.000 x 304	.50 x 2
1/4"	201722SC	0.2500 x 10	6.350 x 254	.50 x 2
	201723SC	0.2500 x 12	6.350 x 304	.50 x 2
17/64"	201742SC	0.2656 x 10	6.746 x 254	.50 x 2
	201743SC	0.2656 x 12	6.746 x 304	.50 x 2
9/32"	201772SC	0.2812 x 10	7.142 x 254	.50 x 2
	201773SC	0.2812 x 12	7.142 x 304	.50 x 2
19/64"	201802SC	0.2969 x 10	7.541 x 254	.50 x 2
	201803SC	0.2969 x 12	7.541 x 304	.50 x 2
5/16"	201852SC	0.3125 x 10	7.937 x 254	.50 x 2
	201853SC	0.3125 x 12	7.937 x 304	.50 x 2

Order Online!

You can now see stock pricing, up to the minute availability, enter orders and so much more!
Visit us at <https://portal.dmetool.com/> to get to started!



Toll Free Tel: 800-658-8855 • Fax: 800-682-3003

GUNDRILL SPEEDS, FEEDS & COOLANT PRESSURES STARTING PARAMETERS (Single Flute)

GUNDRILL DIAMETER	COOLANT PRESSURE			K-MONEL HASTELLOY TUNGSTEN INCOLOY 800-825 REFRACTALOY SFM=80			WASPALOY, A286, RENE, HAYNES INCONEL 600,625 NIMONIC SFM=100			TITANIUM 718 INCONEL MOLLY NITRONIC 40-80 SFM=135			NITRALLOY, GREEK ASCOLOY 400 MONEL 4340 SFM=200			ETD-150, COPPER SFM=275			DUCTILE* SFM=150			BRASS BRONZE SFM=550			
	PSI	RPM	IPM	MAX. UNSUP-PORTED LENGTH	RPM	IPM	MAX. UNSUP-PORTED LENGTH	RPM	IPM	MAX. UNSUP-PORTED LENGTH	RPM	IPM	MAX. UNSUP-PORTED LENGTH	RPM	IPM	MAX. UNSUP-PORTED LENGTH	RPM	IPM	MAX. UNSUP-PORTED LENGTH	RPM	IPM	MAX. UNSUP-PORTED LENGTH	RPM	IPM	MAX. UNSUP-PORTED LENGTH
	0.0550	1800	5556	0.3	4.0	6945	0.3	4.0	9376	0.5	4.0	10000	0.5	4.0	10000	0.5	4.0	10000	0.5	4.0	10000	0.5	4.0	10000	0.5
0.0781	1500	3913	0.4	7.2	4891	0.5	6.6	6603	0.7	5.8	9782	1.0	4.6	10000	1.0	4.6	8560	0.9	5.0	10000	1.0	5.0	10000	1.0	5.0
0.0937	1500	3261	0.5	9.0	4077	0.6	8.0	5504	0.8	6.5	8154	1.2	3.6	10000	1.5	4.6	7134	1.1	6.1	10000	1.5	5.1	10000	1.5	5.1
0.1250	1500	2445	0.4	12.0	3056	0.7	11.0	4126	0.9	9.0	6112	1.4	7.7	8404	1.9	6.5	5348	1.2	8.0	10000	2.3	6.0	10000	2.3	6.0
0.1562	1300	1956	0.6	15.3	2446	0.7	13.7	3302	1.0	11.4	4891	1.5	9.7	6725	2.0	8.2	4280	1.3	10.0	10000	3.0	7.1	10000	3.0	7.1
0.1875	1150	1630	0.6	18.5	2037	0.7	16.6	2750	1.0	14.0	4075	1.4	11.7	5603	2.0	9.9	3565	1.3	12.2	10000	3.5	7.4	10000	3.5	7.4
0.2187	1050	1397	0.6	21.2	1747	0.7	19.0	2358	0.9	15.5	3493	1.4	13.4	4803	1.9	11.4	3057	1.2	14.0	9607	3.8	8.2	9607	3.8	8.2
0.2500	925	1222	0.6	24.9	1528	0.8	22.3	2063	1.0	18.5	3056	1.5	15.7	4202	2.1	13.3	2674	1.3	16.4	8404	4.2	9.6	8404	4.2	9.6
0.2812	850	1087	0.6	28.0	1358	0.8	24.0	1834	1.1	21.0	2717	1.6	17.7	3736	2.2	15.0	2377	1.4	19.0	7472	4.3	10.8	7472	4.3	10.8
0.3125	775	978	0.6	31.2	1222	0.7	28.0	1650	1.0	24.0	2445	1.5	19.7	3362	2.0	16.8	2139	1.3	20.5	6723	4.0	12.0	6723	4.0	12.0
0.3437	725	889	0.6	34.4	1111	0.7	30.0	1500	0.9	26.0	2223	1.4	21.7	3056	1.9	18.2	1945	1.2	23.0	6113	3.9	13.3	6113	3.9	13.3
0.3750	675	815	0.5	37.0	1019	0.7	33.7	1375	0.9	29.5	2037	1.3	23.0	2801	1.8	20.0	1783	1.2	25.0	5603	3.6	14.5	5603	3.6	14.5
0.4062	625	752	0.5	40.8	940	0.6	36.5	1270	0.9	32.0	1881	1.3	25.7	2586	1.8	21.9	1646	1.1	27.3	5172	3.5	15.0	5172	3.5	15.0
0.4375	600	699	0.5	44.0	873	0.6	39.5	1179	0.8	35.0	1746	1.2	27.8	2401	1.6	23.6	1528	1.0	29.5	4802	3.3	17.0	4802	3.3	17.0
0.4687	550	652	0.5	47.0	815	0.6	42.0	1100	0.8	35.0	1630	1.1	29.8	2241	1.6	25.3	1426	1.0	31.5	4483	3.1	18.2	4483	3.1	18.2
0.5000	525	611	0.5	54.0	764	0.5	45.0	1031	0.7	38.0	1528	1.1	31.8	2101	1.5	27.0	1337	0.9	33.6	4202	2.9	19.0	4202	2.9	19.0
0.5312	500	575	0.5	55.0	719	0.5	47.9	971	0.7	40.0	1438	1.0	33.8	1978	1.4	28.7	1258	0.9	36.3	3955	2.9	20.5	3955	2.9	20.5
0.5625	500	543	0.5	56.0	679	0.5	50.8	917	0.7	42.3	1358	1.0	35.8	1868	1.4	30.4	1188	0.9	39.0	3735	2.7	22.0	3735	2.7	22.0
0.5937	475	515	0.4	59.0	643	0.5	53.9	869	0.7	45.0	1287	1.0	38.0	1769	1.3	32.3	1126	0.8	40.7	3539	2.7	23.3	3539	2.7	23.3
0.6250	475	489	0.4	63.6	611	0.5	57.0	825	0.6	48.0	1222	0.9	40.2	1681	1.3	34.2	1070	0.8	42.5	3362	2.5	24.6	3362	2.5	24.6
0.6562	425	466	0.4	66.8	582	0.5	59.0	786	0.6	50.5	1164	0.9	42.0	1601	1.2	36.0	1019	0.8	45.0	3202	2.5	26.0	3202	2.5	26.0
0.6875	425	445	0.4	70.0	556	0.4	62.7	750	0.6	53.0	1111	0.9	44.0	1528	1.2	38.0	972	0.8	50.0	3056	2.4	27.0	3056	2.4	27.0
0.7187	400	425	0.4	73.0	532	0.4	65.0	718	0.6	55.0	1063	0.9	46.0	1462	1.2	39.5	930	0.7	51.0	2923	2.3	28.0	2923	2.3	28.0
0.7500	400	407	0.4	76.3	509	0.4	68.0	688	0.6	57.0	1019	0.8	48.0	1401	1.1	41.0	891	0.7	52.0	2801	2.2	29.0	2801	2.2	29.0
0.8750	350	349	0.4	89.0	437	0.4	79.0	589	0.5	73.0	873	0.8	56.0	1201	1.1	47.0	764	0.7	59.0	2401	2.2	34.0	2401	2.2	34.0
1.0000	310	306	0.4	100	382	0.4	91.0	516	0.5	80.0	764	0.8	64.0	1051	1.1	54.0	669	0.7	68.0	2101	2.1	39.0	2101	2.1	39.0
1.2500	270	244	0.4	126	306	0.4	113	413	0.5	95.0	611	0.6	80.0	840	0.8	68.0	535	0.5	86.0	1681	1.7	49.0	1681	1.7	49.0
1.5000	230	204	0.4	154	255	0.4	138	344	0.5	120	509	0.5	91.0	700	0.7	82.0	446	0.5	105	1401	1.4	60.0	1401	1.4	60.0

*Indicates a two flute drill may be used at two times the recommended feed rate

Dia	FPR	Dia	FPR
0.055-	0.00005	0.500-	0.00070
0.078-	0.00010	0.750-	0.00080
0.156-	0.00030	1.000-	0.00100
0.200-	0.00040	1.250-	0.00100
0.250-	0.00050	1.500-	0.00100

$$RPM = \frac{3.82 \times SFM}{Diameter}$$

$$SFM = \frac{RPM \times Diameter}{3.82}$$

$$FPR \square IPM/RPM$$

$$IPM = FPR \times RPM$$



GUNDRILL SPEEDS, FEEDS & COOLANT PRESSURES STARTING PARAMETERS (Single Flute)

GUNDRILL DIAMETER	COOLANT PRESSURE PSI	8620 SFM=550			416 STAINLESS 4140, 5120 SFM=325			TOOL STEEL SFM=175			15-5, 17-4, 13-8, H-13 455 CUSTOM 303, 304, 310, 316 341, 347, 420, 501 SFM=200			2024AL*, 6061AL* 7075AL* 1010, 1118, 1145 SFM=550			CAST ALUMINUM* SFM=600			GRAY CAST IRON* SFM=200		
		RPM	IPM	MAX. UNSUP-PORTED LENGTH	RPM	IPM	MAX. UNSUP-PORTED LENGTH	RPM	IPM	MAX. UNSUP-PORTED LENGTH	RPM	IPM	MAX. UNSUP-PORTED LENGTH	RPM	IPM	MAX. UNSUP-PORTED LENGTH	RPM	IPM	MAX. UNSUP-PORTED LENGTH	RPM	IPM	MAX. UNSUP-PORTED LENGTH
		0.0550	1800	10000	0.5	4.0	10000	0.5	4.0	10000	0.5	4.0	10000	0.5	4.0	10000	0.5	4.0	10000	0.5	4.0	10000
0.0781	1500	10000	1.0	4.6	10000	1.0	4.6	8560	0.9	4.6	9782	1.0	4.6	10000	1.0	4.6	10000	1.0	4.6	9782	1.0	4.6
0.0937	1500	10000	1.5	5.0	10000	1.5	5.0	7134	1.1	6.0	8154	1.2	5.0	10000	1.5	5.0	10000	1.5	5.0	8154	1.2	5.0
0.1250	1500	10000	2.0	6.0	9932	2.0	6.0	5348	1.1	8.0	6112	1.2	7.7	10000	2.0	6.0	10000	2.0	6.0	6112	1.2	7.7
0.1562	1300	10000	3.0	6.7	7948	2.4	7.7	4280	1.3	10.3	4891	1.5	9.7	10000	3.0	6.6	10000	3.0	6.6	4891	1.5	9.7
0.1875	1150	10000	3.5	7.5	6621	2.3	9.2	3565	1.2	12.4	4075	1.4	11.7	10000	3.5	7.5	10000	3.5	7.5	4075	1.4	11.7
0.2187	1050	9607	3.8	8.2	5677	2.3	10.6	3057	1.2	14.2	3493	1.4	13.4	9607	3.8	8.2	10000	4.0	7.8	3493	1.4	13.4
0.2500	925	8404	4.2	9.6	4966	2.5	12.4	2674	1.3	16.5	3056	1.5	15.7	8404	4.2	9.6	9168	4.6	9.1	3056	1.5	15.7
0.2812	850	7472	4.1	10.8	4415	2.3	14.0	2377	1.2	18.7	2717	1.4	17.7	7472	3.9	10.8	8151	4.2	10.3	2717	1.4	17.7
0.3125	775	6723	4.0	12.0	3973	2.4	15.6	2139	1.3	20.9	2445	1.5	19.7	6723	4.0	12.0	7334	4.4	11.5	2445	1.5	19.7
0.3437	725	6113	3.9	13.3	3612	2.3	17.2	1945	1.2	23.0	2223	1.4	21.7	6113	3.9	13.3	6669	4.2	12.6	2223	1.4	21.7
0.3750	675	5603	3.6	14.5	3311	2.2	18.8	1783	1.2	26.0	2037	1.3	23.2	5603	3.6	14.5	6112	4.0	13.8	2037	1.3	23.2
0.4062	625	5172	3.5	15.0	3056	2.1	19.6	1646	1.1	27.3	1881	1.3	25.7	5172	3.5	15.0	5643	3.8	14.2	1881	1.3	25.7
0.4375	600	4802	3.3	17.0	2838	1.9	21.9	1528	1.0	29.4	1746	1.2	27.8	4802	3.3	17.0	5239	3.6	16.1	1746	1.2	27.8
0.4687	550	4483	3.1	18.2	2649	1.9	23.5	1426	1.0	31.5	1630	1.1	29.8	4483	3.1	18.2	4890	3.4	17.3	1630	1.1	29.8
0.5000	525	4202	2.9	19.3	2483	1.7	25.1	1337	0.9	33.7	1528	1.1	31.8	4202	2.9	19.3	4584	3.2	18.5	1528	1.1	31.8
0.5312	500	3955	2.9	20.6	2337	1.7	26.7	1258	0.9	35.8	1438	1.0	33.8	3955	2.9	20.6	4315	3.1	19.6	1438	1.0	33.8
0.5625	500	3735	2.7	21.9	2207	1.6	28.3	1188	0.9	37.9	1358	1.0	35.8	3735	2.7	21.9	4075	3.0	20.8	1358	1.0	35.8
0.5937	475	3539	2.7	23.2	2091	1.6	30.0	1126	0.8	40.2	1287	1.0	38.0	3539	2.7	23.2	3861	2.9	22.1	1287	1.0	38.0
0.6250	475	3362	2.5	24.6	1986	1.5	31.8	1070	0.8	42.6	1222	0.9	40.2	3362	2.5	24.6	3667	2.8	23.4	1222	0.9	40.2
0.6562	425	3202	2.5	25.8	1892	1.5	37.8	1019	0.8	44.5	1164	0.9	42.2	3202	2.5	25.8	3493	2.7	24.5	1164	0.9	42.2
0.6875	425	3056	2.4	27.0	1806	1.4	39.0	972	0.8	46.5	1111	0.9	44.2	3056	2.4	27.0	3334	2.6	25.7	1111	0.9	44.2
0.7187	400	2923	2.3	28.2	1727	1.4	41.5	930	0.7	48.7	1063	0.9	46.2	2923	2.3	28.2	3189	2.6	26.8	1063	0.9	46.2
0.7500	400	2801	2.2	29.5	1655	1.3	42.7	891	0.7	51.0	1019	0.8	48.2	2801	2.2	29.5	3056	2.4	28.0	1019	0.8	48.2
0.8750	350	2401	2.2	34.4	1419	1.3	44.5	764	0.7	59.5	873	0.8	56.2	2401	2.2	34.4	2619	2.4	32.7	873	0.8	56.2
1.0000	310	2101	2.1	39.0	1242	1.2	50.9	669	0.7	68.0	764	0.8	64.0	2101	2.1	39.3	2292	2.3	37.0	764	0.8	64.0
1.2500	270	1681	1.7	49.0	993	1.0	63.0	535	0.5	84.0	611	0.6	80.0	1681	1.7	50.0	1834	1.8	46.0	611	0.6	80.0
1.5000	230	1401	1.4	59.0	828	0.8	77.0	446	0.4	102	509	0.5	91.0	1401	1.4	59.0	1528	1.5	56.0	509	0.5	97.0

**Indicates a two flute drill may be used at two times the recommended feed rate*

Dia	FPR	Dia	FPR
0.055-	0.00005	0.500-	0.00070
0.078-	0.00010	0.750-	0.00080
0.156-	0.00030	1.000-	0.00100
0.200-	0.00040	1.250-	0.00100
0.250-	0.00050	1.500-	0.00100

$$RPM = \frac{3.82 \times SFM}{Diameter}$$

$$SFM = \frac{RPM \times Diameter}{3.82}$$

$$FPR \square IPM/RPM$$

$$IPM = FPR \times RPM$$

GUNDRILL PROBLEM SOLVING

Tool Faults

Hole Faults

Possible Cause	Tool Faults										Hole Faults							
	Outside Point Wear	Wear Pad Erosion	Built Up Edge	Cratering	Margin Wear	Flank Wear	Poor Tool Life	Tool Pick Up	Tool Chipping	Tool Breakage	Poor Finish	Hole Run-out	Tight Exit	Bell Mouthed	Banana Shaped	Out of Round	Under-sized	Over-sized
Bushing																		
Clamping unsuitable																		
Oversized				●														
Undersized																●		
Workpiece not against bushing							●											●
Coolant																		
Incorrect grade		●	●	●	●			●			●							
Insufficient flow						●		●			●							●
Loss of pressure								●	●			●					●	
Overheating								●	●									
High pressure																		●
Low pressure								●	●									
Feed																		
Erratic								●			●							●
Excessive			●	●		●	●						●	●				
Insufficient											●							
Material																		
Grain structure	●		●				●		●	●						●		
Heat treatment faults	●		●				●		●	●								
Overheating and closing In Thin wall section																●	●	
Misalignment		●			●		●					●						●
Poor Braze																		●
Rough Grind On Cutting Edges								●			●							
Spindle																		
Speed high	●							●										
Speed low			●	●														
Tight Hole Tool																		
Built up edge																		●
Chip control inadequate																		●
Insufficient clearance									●					●				
Incorrect contour (profile)								●	●									●
Excessive inside angle pressure																		●
Excessive outside angle pressure													●				●	
Incorrect geometry	●							●										
Heel drag													●					
Overworked (need regrind)						●												●
Whip													●	●	●			●
Vibration																		
Mechanical										●								
Oil																		
Wear Pad Cutting								●										●



OPERATION FORMULAS

D = Drill Diameter (inch)

IPM	= Inches Per Minute	IPR x RPM	= IPM
IPR	= Inches Per Revolution	IPM/RPM	= IPR
RPM	= Revolutions Per Minute	(SFM x 3.82)/D	= RPM
SFM	= Surface Feet Per Minute	D x RPM x .26	= SFM

D = Drill Diameter (mm)

FPM	= mm Per Minute	FPR x RPM	= FPM
FPR	= Feed Per Revolution	FPM/RPM	= FPR
RPM	= Revolutions Per Minute	(SMM x 318.5)/D	= RPM
SMM	= Surface Meter Per Minute	(3.14 x D x RPM)/1000	= SMM

CONVERSIONS

Inch x 25.4	= mm	SFM x .3048	= SMM
mm x .0394	= Inch	SMM x 3.281	= SFM

Special Diameter, Length, Coatings, Tool Geometry are available upon request

We can design drill for your specific applications

Quick turnaround is available - From 3-5 Days

Resharpener is available - Competitors' tools are welcomed

**Please call 800-658-8855 or fax 800-682-3003
or email info@dmtool.com**

CUSTOMER WORKSHEET FOR STANDARD GUNDRILL

NOSEGRIND

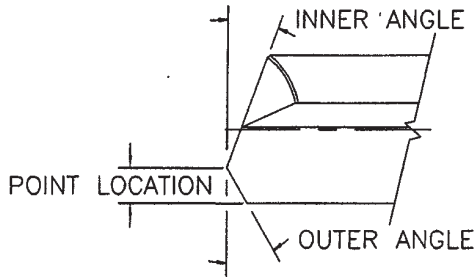

N - 8

ELDORADO STOCK DRILL
GRIND ALL-PURPOSE
GRIND FOR STEEL, INCONEL
AND STAINLESS STEEL.
MOST OFTEN USED WITH
STOCK "R1" O.D. CONTOUR.

N - 4

IN ALUMINUM AND BRASS
USE THIS GRIND WITH "R4"
OR "R2" O.D. CONTOUR
FOR BEST HOLE FINISH.

N - 73

FOR DRILLING CAST IRON,
STACKED PARTS AND ANGULAR
ENTRIES, STRONGEST POINT IN
GUNDRILLING DUE TO
PLACEMENT NEAR CENTER
AWAY FROM HIGHEST SURFACE
FEET/MINUTE AT CORNER.

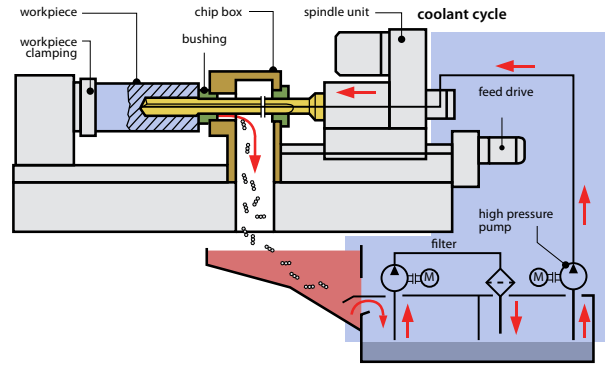

STANDARD DRIVERS

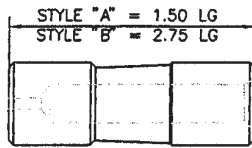

STYLE "A" & "B"
TAPERED UNDERCUT

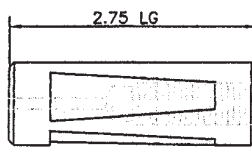

STYLE "C"
(2) TAPERED FLATS

STOCK DRIVER SELECTION

TIP DIA RANGE	DRIVER STYLE	LENGTH	DIAMETER
.4479	2" TAPERED CUT	1.5	.4998/.4993
.6479	2" TAPERED CUT	2.75	.7498/.7493
.7899	(2) TAPERED FLATS	2.75	.9998/.9993
1.0549	(2) TAPERED FLATS	2.75	1.2498/1.2493
1.3899	(2) TAPERED FLATS	2.75	1.4998/1.4993

CONTOUR STYLE



R1 STANDARD

ALL PURPOSE STOCK DRILL CONTOUR
FOR STEEL, STAINLESS STEEL,
INCONEL (ALUMINUM, WHEN SIZE AND
FINISH NOT CRITICAL) OFFERS MINIMUM
BEARING CONTACT WITH WORKPIECE
(NON-MICABLE)



R2 STD. BEARING PAD + GUIDE PAD

RECOMMENDED FOR ALL NON-FERROUS
AND CAST IRON UP TO GUNDRILL DIA.
OF .200 (NON-MICABLE)

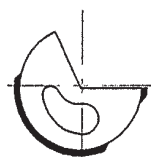

R3 HIGH BEARING PAD

FOR GOOD SIZE CONTROL (INCLUDING
EXIT) SPECIAL PURPOSE CONTOUR,
WHERE MICABLE DIA. IS REQUIRED OR
EXTRA BURNISHING ACTION IS REQUIRED,
NOT FOR ALL MATERIALS (MICABLE)

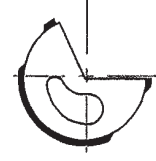

R4 HIGH BEARING PAD + GUIDE PAD

FOR USE IN ALUMINUM AND BRASS FOR BEST
HOLE FINISH AND FOR INTERSECTING HOLES
AND INTERRUPTED CUTS, OR EXTRA O.D
SUPPORT AND BURNISHING IS REQUIRED. USE
WITH WOOD AND PLASTIC IN COMBINATION
WITH .0015/.002 BACK TAPER. DO NOT USE
IN HIGH NICKEL CONTENT MAT'LS DUE TO
HIGH BURNISHING FORCES (MICABLE)

THREE-PIECE CONSTRUCTION

DIMENSIONS NOT SHOWN ARE MFG STANDARDS

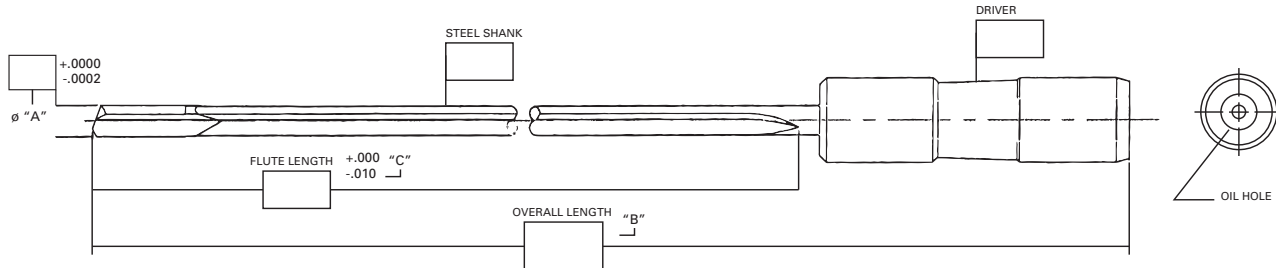

CARBIDE DIAMETER "A" _____ MATERIAL _____

OVERALL LENGTH "B" _____ MACHINE _____

FLUTE LENGTH "C" _____ SPEED _____

OIL HOLE TYPE = KIDNEY _____ 2 HOLE _____ FEED _____

SPECIAL DRIVER _____ COOLANT _____

CUSTOMER NAME - PRINT

TOOL#

SEND TO SALES@DMETOOL.COM OR FAX 203.878.6156

QTY

CUSTOMER PO#

DATE

CUSTOMER WORKSHEET FOR SOLID CARBIDE GUNDRILL

NOSEGRIND

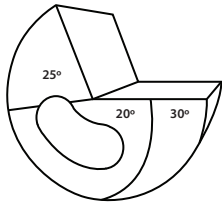

N - 8

GENERAL PURPOSE STOCK DRILL GRIND FOR STEEL, INCONEL AND STAINLESS STEEL, MOST OFTEN USED WITH STOCK 'R1' O.D. CONTOUR.

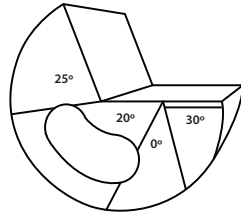

FACET

FACET GRINDS ARE PREFERRED ON SPECIFIC APPLICATIONS, OR WHEN REGRIND FIXTURES LIMIT THE CAM TYPE SHARPENINGS. THEY CAN BE GROUND TO VARIOUS SLASH TYPE ANGLES WITH GOOD PERFORMANCE AND ALLOW A GREATER AMOUNT OF CLEARANCE FOR COOLANT TO COOL THE CHIP AT THE CUTTING EDGE. THIS GRIND IS STANDARD ON MOST EUROPEAN APPLICATIONS.

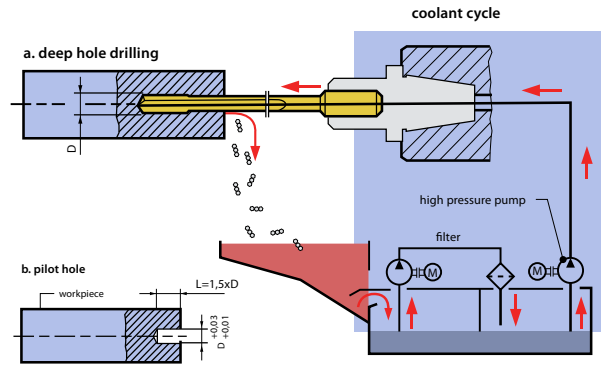

A PILOT HOLE IS NEEDED IF A GUNDRILL INSERT IS NOT BEING USED. THE GENERAL RULE IS ONE-TO-TWO TIMES DIAMETER IN DEPTH AND .0002"-.0005" LARGER IN DIAMETER AND A BOTTOM FORM IS PREFERRED

STANDARD SOLID CARBIDE DRIVERS

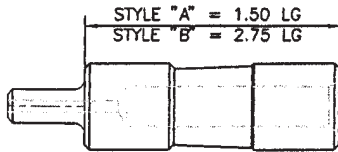

STYLE "A" = 1.50 LG
STYLE "B" = 2.75 LG

STYLE "A" & "B"
TAPERED UNDERCUT

**SPECIAL CUSTOM DRIVERS
AVAILABLE TO ORDER IN
3mm 6mm 8mm**

CONTACT US FOR MORE INFORMATION

STOCK DRIVER SELECTION

TIP DIA RANGE	DRIVER STYLE	LENGTH	DIAMETER
.0394 TO .3125	2" TAPERED CUT	1.5	.5000

CONTOUR STYLE



R1 STANDARD

ALL PURPOSE STOCK DRILL CONTOUR FOR STEEL, STAINLESS STEEL, INCONEL, (ALUMINUM, WHEN SIZE AND FINISH NOT CRITICAL) OFFERS MINIMUM BEARING CONTACT WITH WORKPIECE (NON-MICABLE)



R2 STD. BEARING PAD + GUIDE PAD

RECOMMENDED FOR ALL NON-FERROUS AND CAST IRON UP TO GUNDRILL DIA. OF .200 (NON-MICABLE)

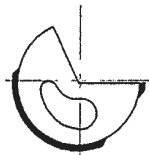

R3 HIGH BEARING PAD

FOR GOOD SIZE CONTROL (INCLUDING EXIT) SPECIAL PURPOSE CONTOUR, WHERE MICABLE DIA. IS REQUIRED OR EXTRA BURNISHING ACTION IS REQUIRED, NOT FOR ALL MATERIALS (MICABLE)



R4 HIGH BEARING PAD + GUIDE PAD

FOR USE IN ALUMINUM AND BRASS FOR BEST HOLE FINISH AND FOR INTERSECTING HOLES AND INTERRUPTED CUTS, OR EXTRA O.D. SUPPORT AND BURNISHING IS REQUIRED. USE WITH WOOD AND PLASTIC IN COMBINATION WITH .0015/.002 BACK TAPER. DO NOT USE IN HIGH NICKEL CONTENT MAT'LS DUE TO HIGH BURNISHING FORCES (MICABLE)

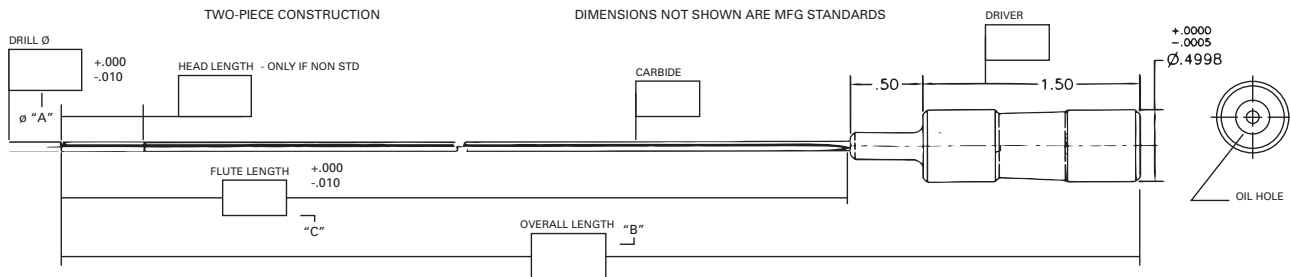

CARBIDE DIAMETER "A" _____ MATERIAL _____

OVERALL LENGTH "B" _____ MACHINE _____

FLUTE LENGTH "C" _____ SPEED _____

OIL HOLE TYPE = KIDNEY _____ FEED _____

SPECIAL DRIVER _____ COOLANT _____

CUSTOMER NAME - PRINT

TOOL#

SEND TO SALES@DMETOOL.COM OR FAX 203.878.6156

QTY

CUSTOMER PO#

DATE

DRILL MASTERS Eldorado Tool

336 Boston Post Road, Milford, CT 06460 USA

Tel: 203-878-1711 • 800-658-8855 Fax: 203-878-6156 • 800-682-3003

dmetool.com



COMPACT 070 958722 828 438 173 22 0000448
252 010 858723 306 450 171 2200449 010 858
410 858724 306 450 171 2200450 010 858