

Single Lip drills with indexable inserts

WP-ELB Series 10

Main Advantages:

1. **Versatility to use** on lathe, machining centers and deep hole machines.
1. **High efficiency** by specifically developed cutting edge geometry for ideal chip formation.
1. **Short downtime** resulting from quick exchange of wear parts
2. **Easy to use**, no sharpening, no length adjustment, easy inventory of wear parts.
3. **Long tool life** due to full coating, edge treatment and indexable design
4. **Quick availability** due to stocked wear parts and most common body sizes.



Design:

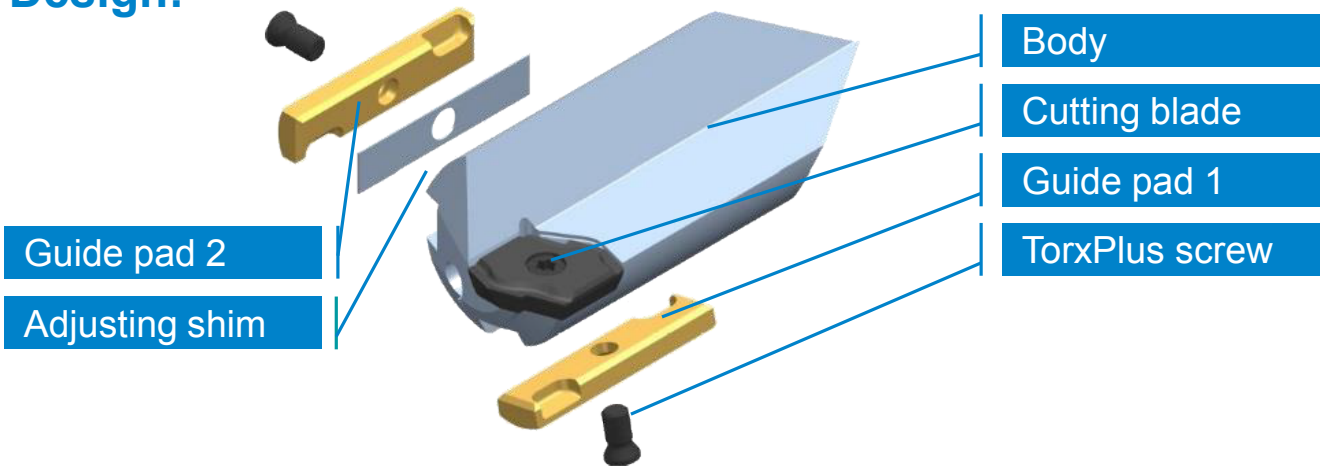

Technical Information:

- Diameter range: 12.00 mm – 28.00 mm
- Cutting blade & guide pads fully coated
- Covering the whole diameter range with only 6 sizes of cutting blades.
- Tool body built in steps of 0.1 mm
- Available with long head and three additional guide
- Adjusting shim available to fine-tune diameter



Single Lip drills with indexable inserts

WP-ELB Series 10

Inquiries and delivery:

- Please state the required drill diameter, the overall length and the clamping element.
- You will receive your tools fully equipped and ready to use.
- Suitable TorxPlus® drivers for the replacement of wear parts are available as extra

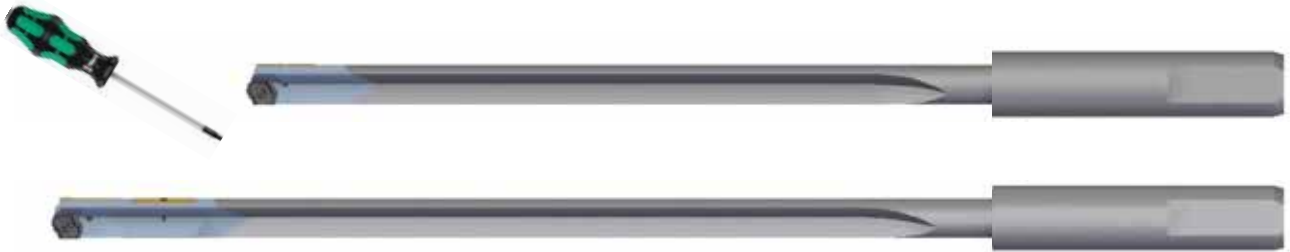

HEADS IN STOCK SHORT AND LONG

0.4724	INDEXABLE	0.5512	INDEXABLE	0.6250	INDEXABLE	0.7187	INDEXABLE	0.8125	INDEXABLE	0.9844	INDEXABLE
0.4844	INDEXABLE	0.5625	INDEXABLE	0.6299	INDEXABLE	0.7500	INDEXABLE	0.8750	INDEXABLE	1.000	INDEXABLE
0.5000	INDEXABLE	0.5781	INDEXABLE	0.6719	INDEXABLE	0.7656	INDEXABLE	0.9062	INDEXABLE	1.0625	INDEXABLE
0.5156	INDEXABLE	0.5937	INDEXABLE	0.6875	INDEXABLE	0.7812	INDEXABLE	0.9219	INDEXABLE		
0.5312	INDEXALBE	0.6094	INDEXABLE	0.7031	INDEXALBE	0.7874	INDEXABLE	0.9687	INDEXALBE		

Wear Parts overview:

Drill Ø		Cutting insert	Screw Torx Plus®	Guide pad	Screw Torx Plus®	Adjusting shim
von	bis					
12,00	13,99	TSTS-CB2-00 TSTS000199	6IP M2,2x4 TSTS000613	TSTS-GC04A-P TSTS000326	6IP M2,2x4 TSTS000613	TSTS-S04
14,00	15,09	TSTS-CB2-01 TSTS000094	6IP M2,2x4,6 TSTS000614	TSTS-GC05A-P TSTS000091	6IP M2,2x4,6 TSTS000633	TSTS-S05
15,10	17,39	TSTS-CB2-02 TSTS000095	7IP M2,5x5 TSTS000615		7IP M2,5x5 TSTS000615	
17,40	19,79	TSTS-CB2-05 TSTS000098	7IP M3x6 TSTS000616	TSTS-GC06-P TSTS000016	7IP M3x6 TSTS000616	TSTS-S06
19,80	23,89	TSTS-CB2-07 TSTS000100				
23,90	28,09	TSTS-CB2-08 TSTS000181				